

2020 JIM VLOCK BUILDING PROJECT

484 DIXWELL AVENUE | NEW HAVEN, CT 06511

PERMIT SET

SHEET LIST

A0.0	COVER SHEET
A0.1	DEMO + SITE PREPARATION PLAN
A0.2	SITE PLAN
A0.3	WEST DIVISION STREET ELEVATION
A0.4	ARCHITECTURAL SITE PLAN
A1.0	FLOOR PLAN
A1.1	ROOF PLAN
A1.2	REFLECTED CEILING PLAN
A2.0	BUILDING ELEVATION - NORTH
A2.1	BUILDING ELEVATION - EAST, WEST
A2.2	BUILDING ELEVATION - SOUTH
A2.3	WINDOW + DOOR SCHEDULE
A3.0	BUILDING SECTION - LIVING/DINING
A3.1	BUILDING SECTION - BED/BATH
A3.2	BUILDING SECTION - LONGITUDINAL, WEST
A3.3	BUILDING SECTION - LONGITUDINAL, EAST
S1.0	SLAB PLAN
S1.1	SILL PLATE PLAN
S1.2	WALL FRAMING PLAN
S1.3	ROOF FRAMING PLAN
S2.0	FRAMING ELEVATION - NORTH
S2.1	FRAMING ELEVATION - EAST, WEST
S2.2	FRAMING ELEVATION - SOUTH
C1.0	STD NH-02 GRANITE CURB
C1.1	STD NH-02A BITUMINOUS CONCRETE LIP CURB
C1.2	STD NH-03 TYPICAL CONCRETE DRIVEWAY
C1.3	STD NH-03A TYPICAL CONCRETE DRIVEWAY
C1.4	STD NH-04 TYPICAL SIDEWALK DETAILS
C1.5	STD NH-32B TREE PROTECTION NOTES
C1.6	STD NH-32C RECOMMENDED TREE TYPES
C1.7	STD NH-33 SEDIMENT + EROSION CONTROL
C1.8	STD NH-33A SEDIMENT + EROSION CONTROL
C1.9	STD NH-36 ANTI-TRACKING PAD

PROJECT INFO

SITE ADDRESS:	484 DIXWELL AVENUE NEW HAVEN, CT 06511
OWNER:	COLUMBUS HOUSE 586 ELLA T. GRASSO BOULEVARD NEW HAVEN, CT 06519
PARCEL:	292 0390 03100
BUILDING CODE:	2018 CONNECTICUT STATE BUILDING CODE
JURISDICTION:	CITY OF NEW HAVEN
ZONING:	RM-2, HIGH-MIDDLE DENSITY

ZONING INFO

DWELLING UNITS:	2 UNITS
LOT AREA:	5663 SQ FT
AVERAGE LOT WIDTH:	77'-4"
LOT AREA PER UNIT:	2831 SQ FT
BUILDING COVERAGE:	1009 SQ FT, 18% OF LOT AREA
BUILDING HEIGHT:	11'-4", 1 STORY
FRONT YARD SETBACK:	17'
REAR YARD SETBACK:	25'
SIDE YARD SETBACK:	8' AND 10'
PARKING:	3 PARKING SPACES TO BE PROVIDED AT 324 WEST DIVISION STREET AS PER CONSULTATION WITH ZONING COMPLIANCE OFFICER

LOCATION PLAN



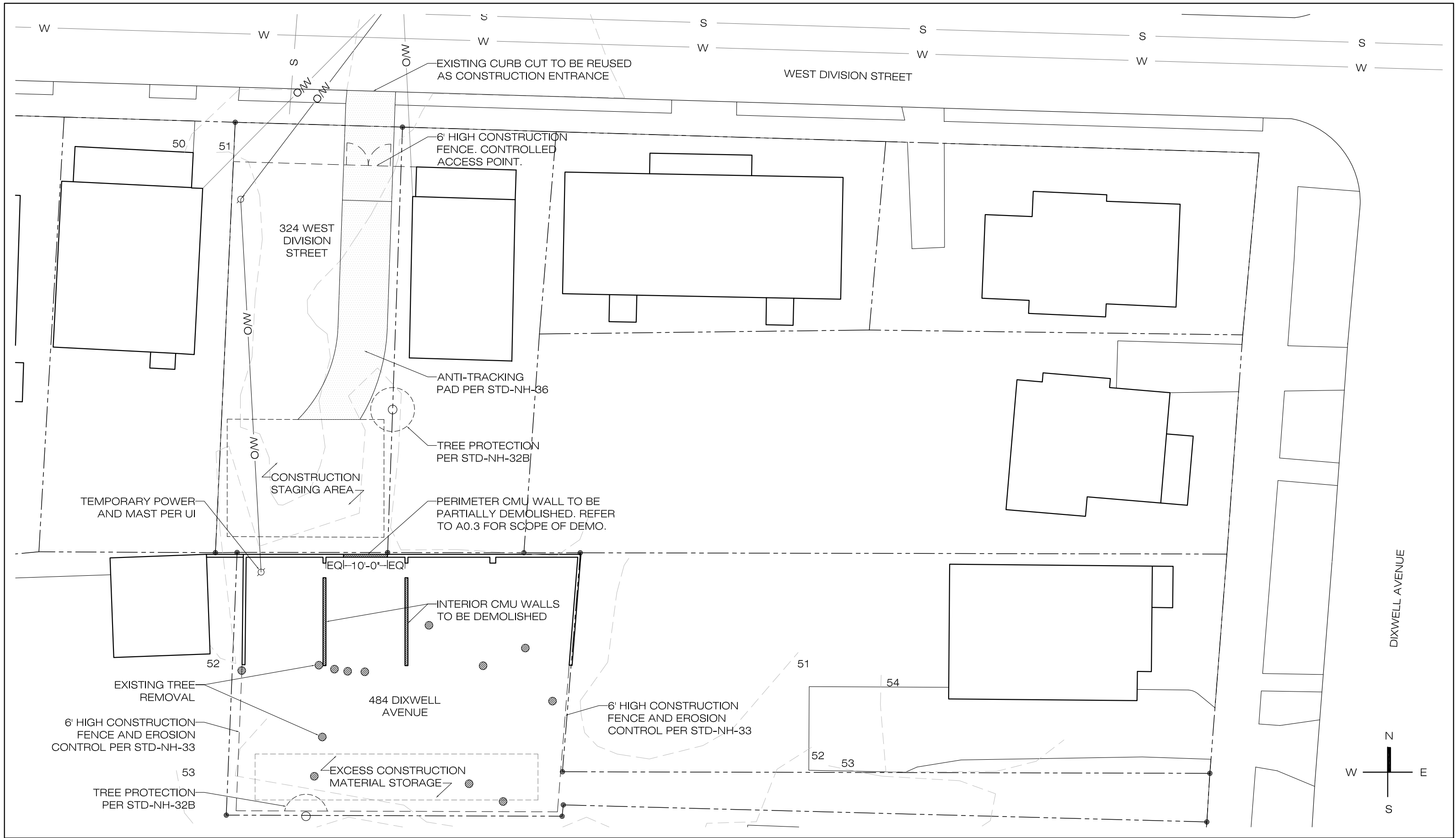

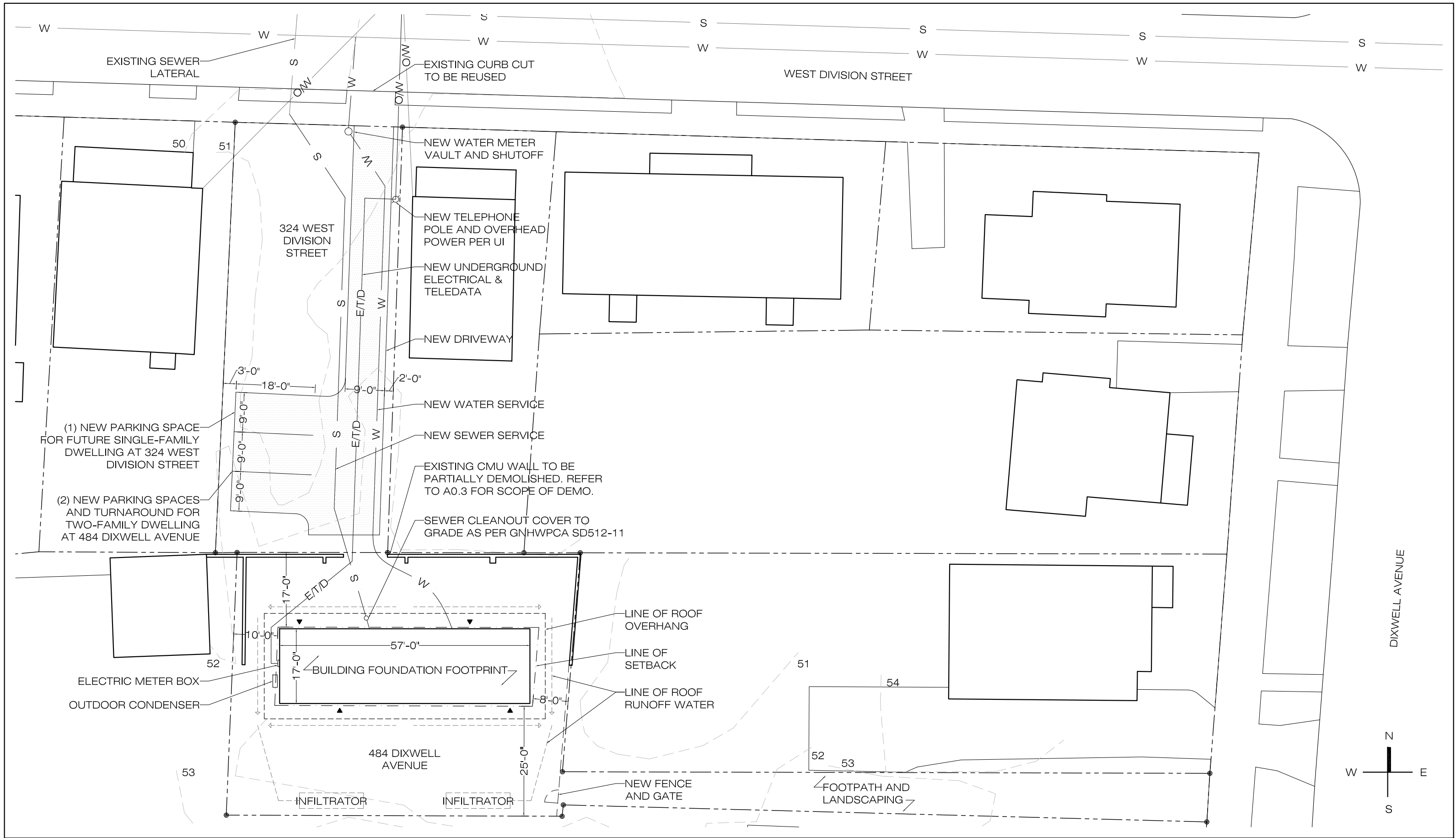

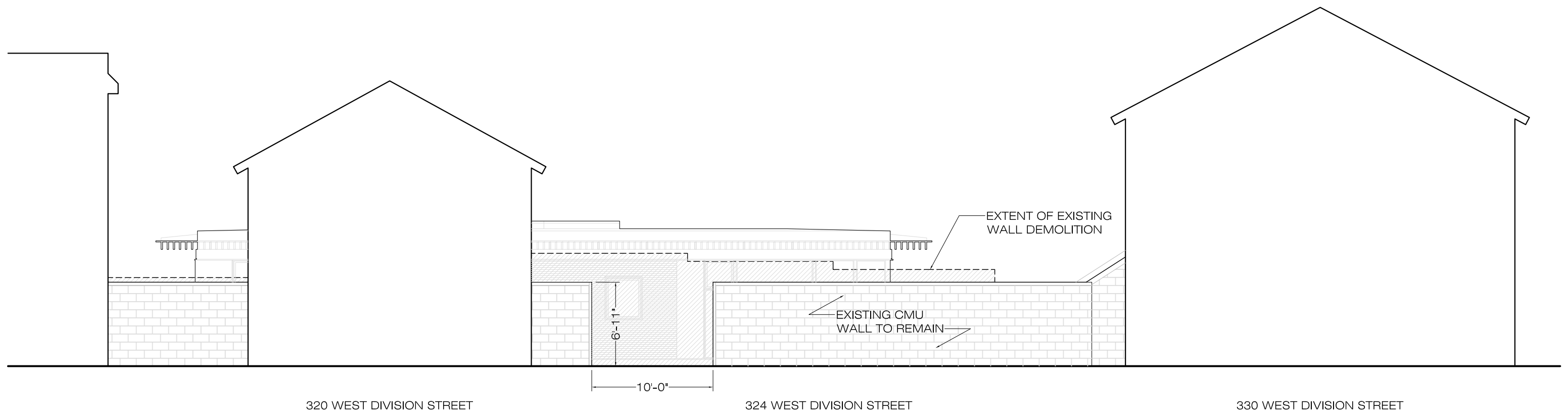

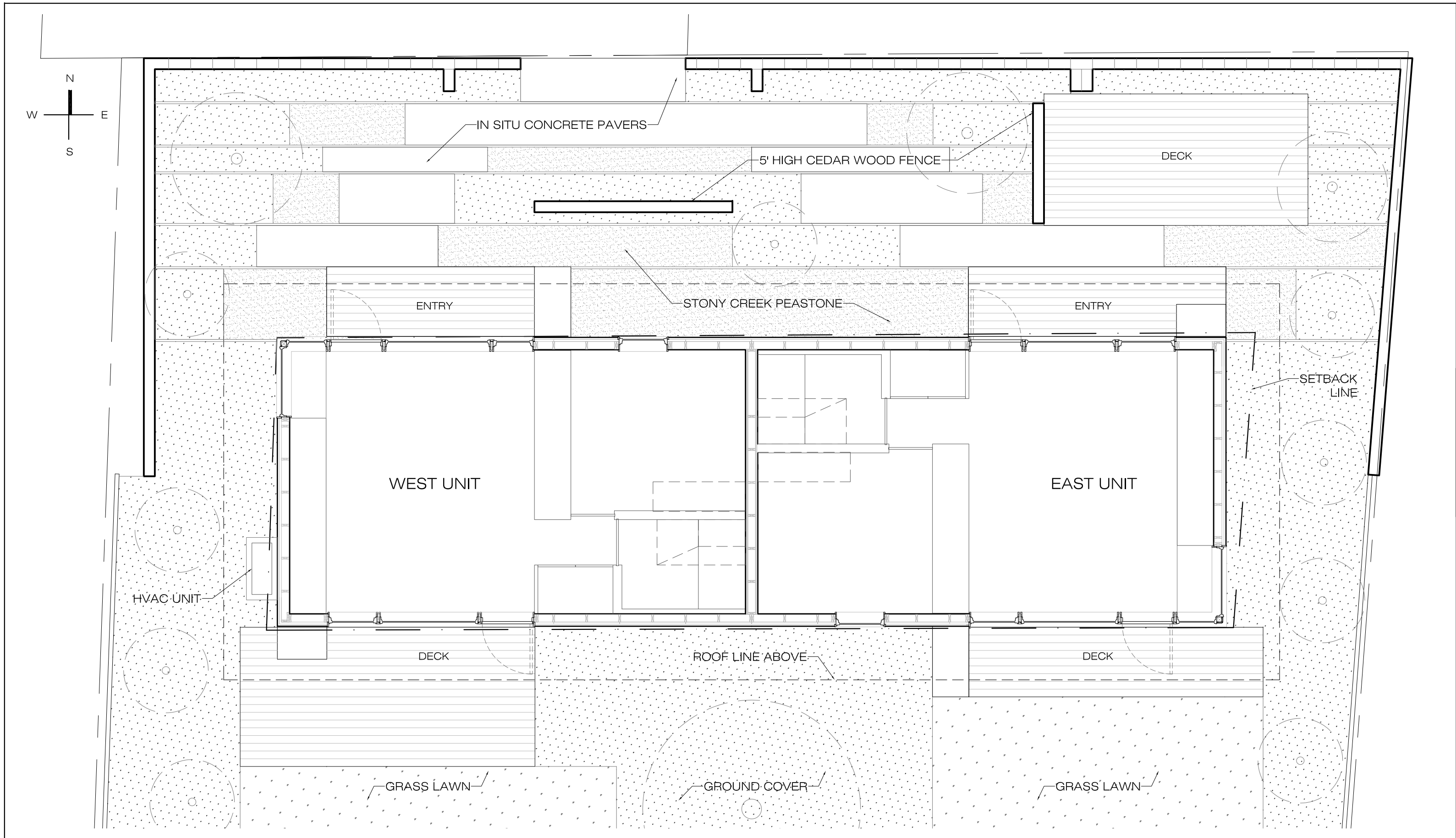

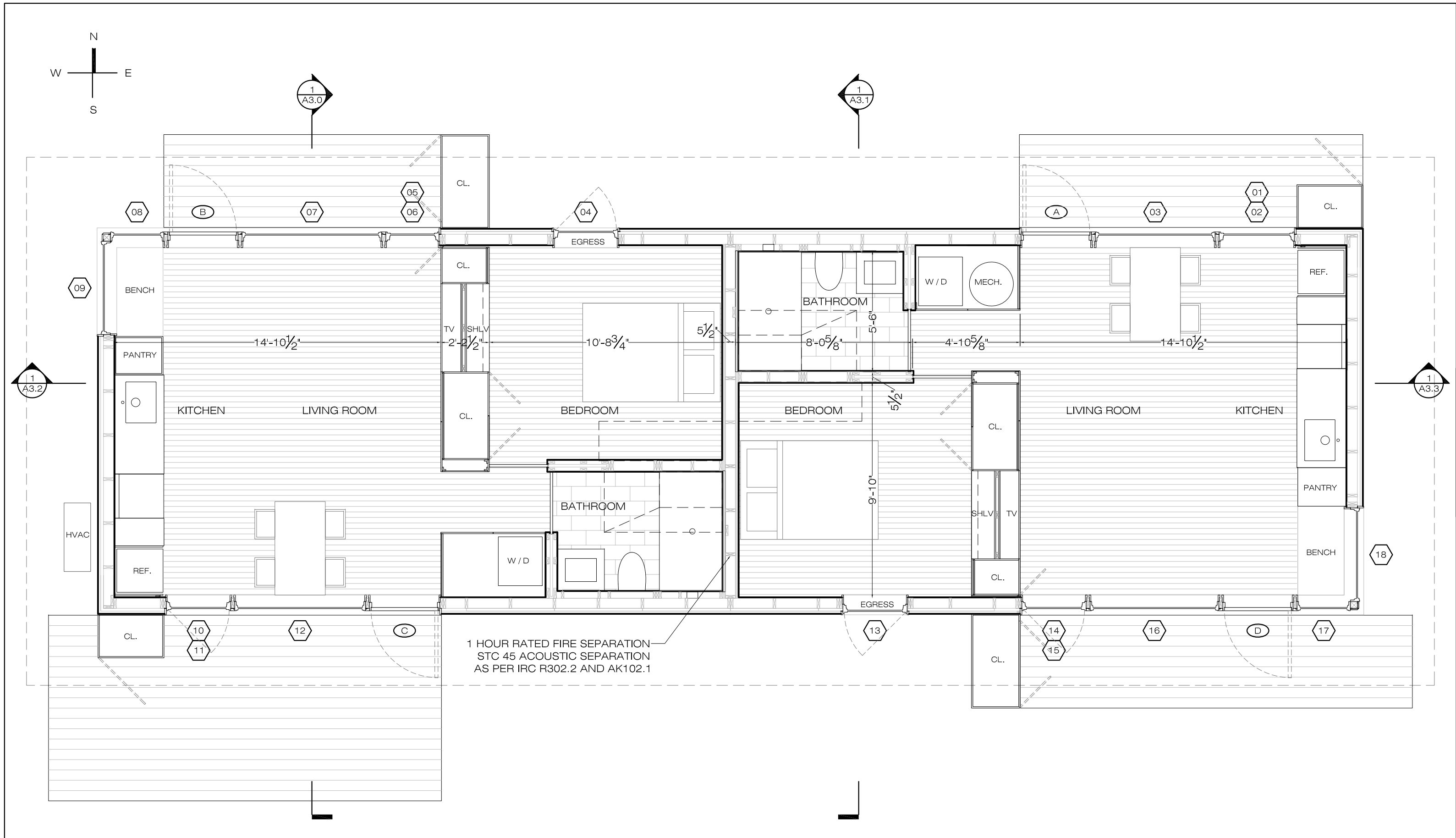

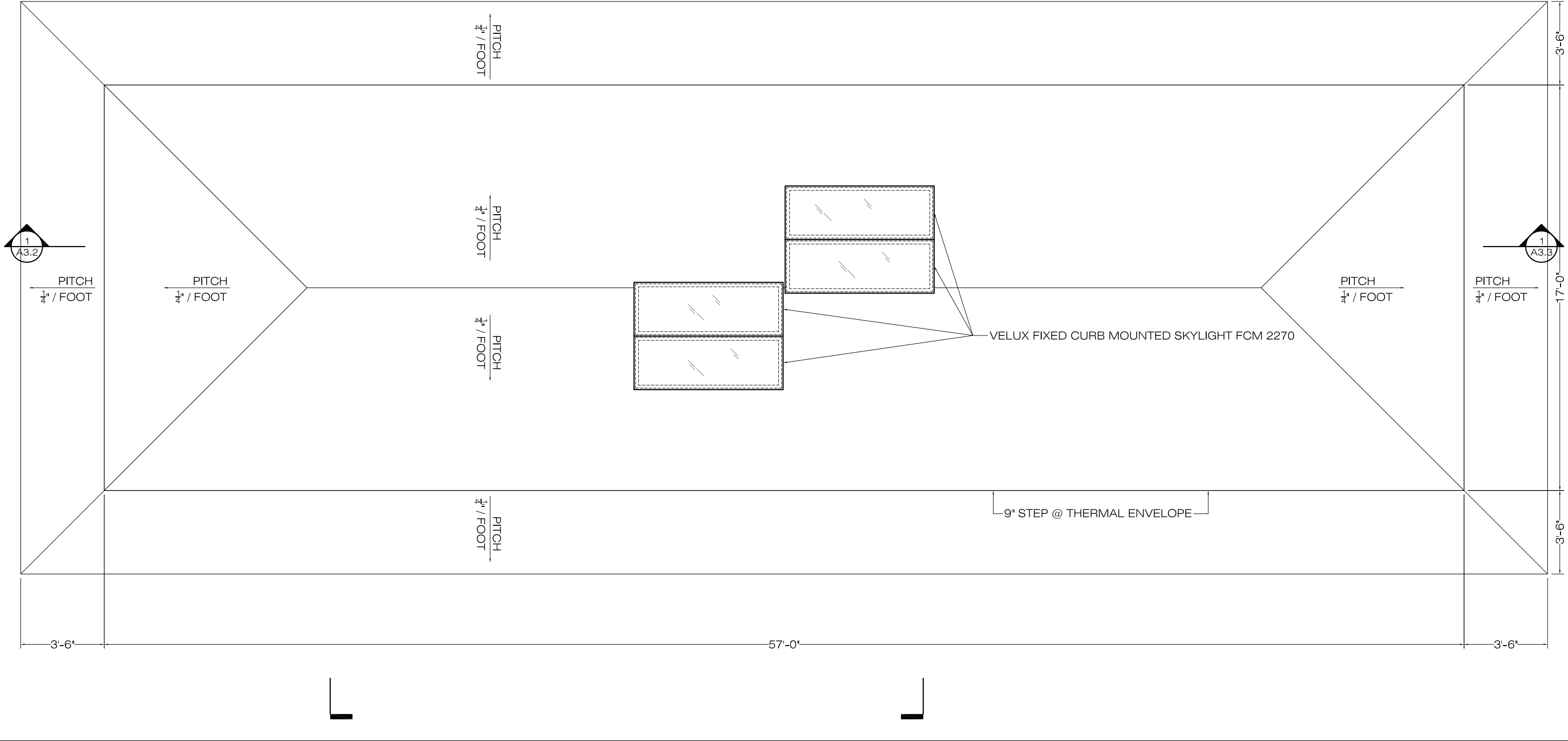
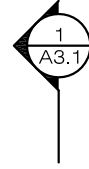
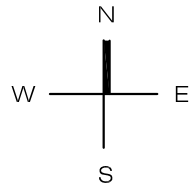

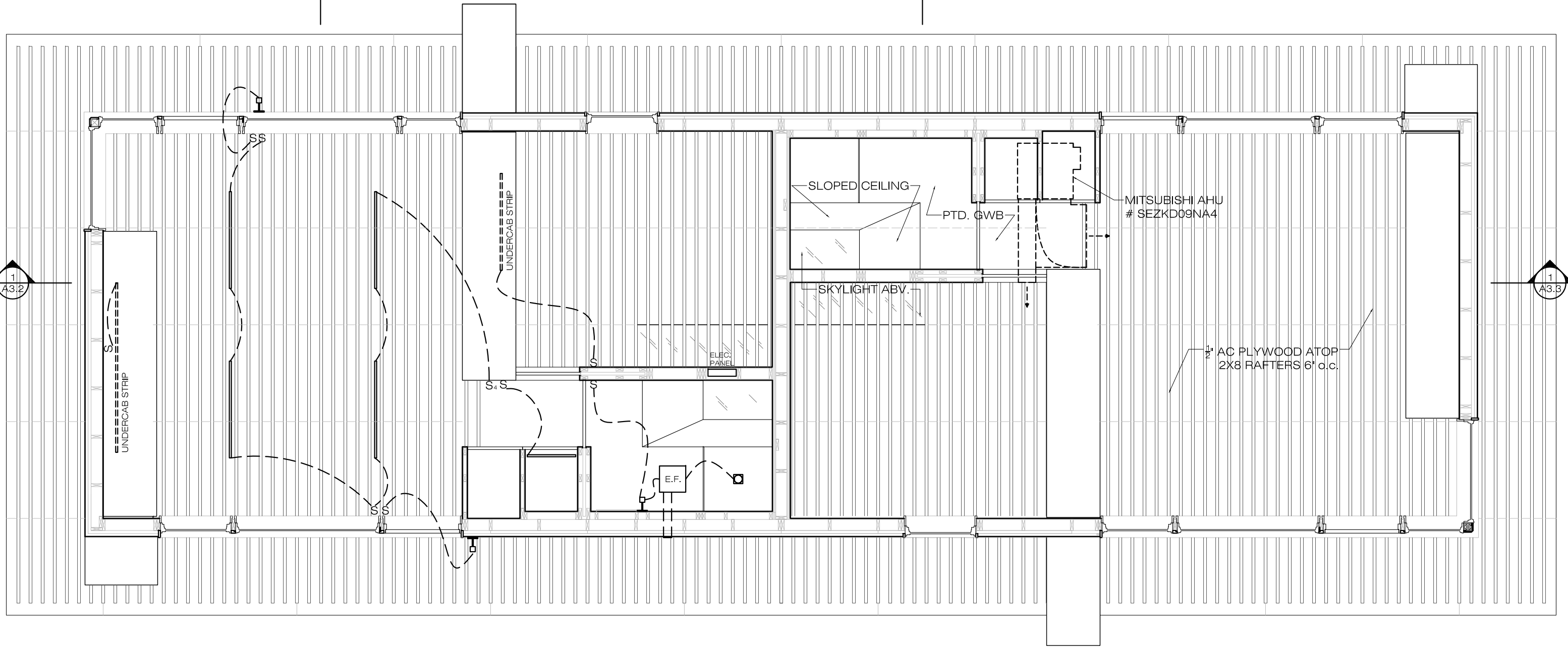
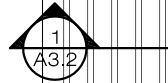
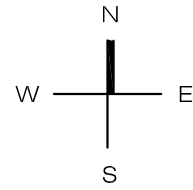

NOTE: WEST UNIT SHOWS LIGHTING, EAST UNIT SHOWS MATERIALITY & HVAC; PLANS ARE MIRRORED

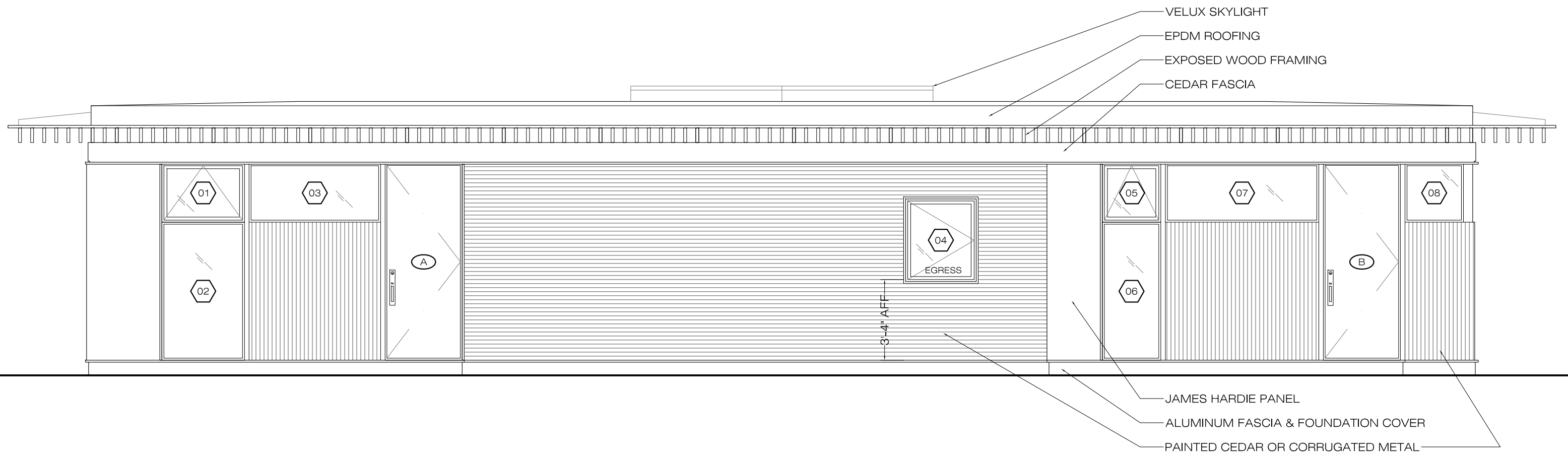

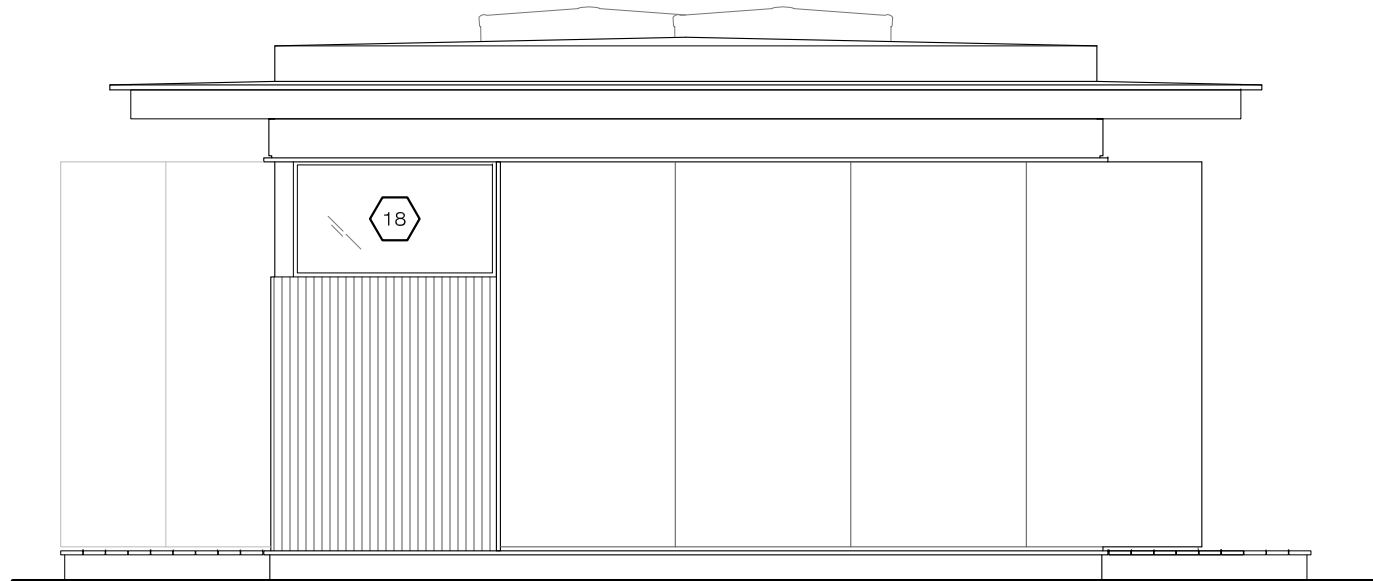
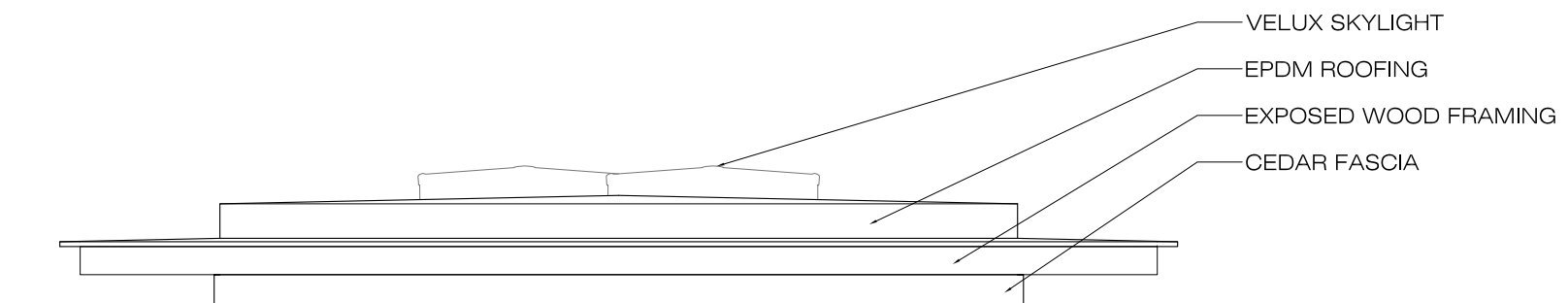

- JAMES HARDIE PANEL
- MITSUBISHI CONDENSER UNIT
- ALUMINUM FACIA & FOUNDATION COVER
- PAINTED CEDAR OR CORRUGATED METAL

WEST ELEVATION

EAST ELEVATION

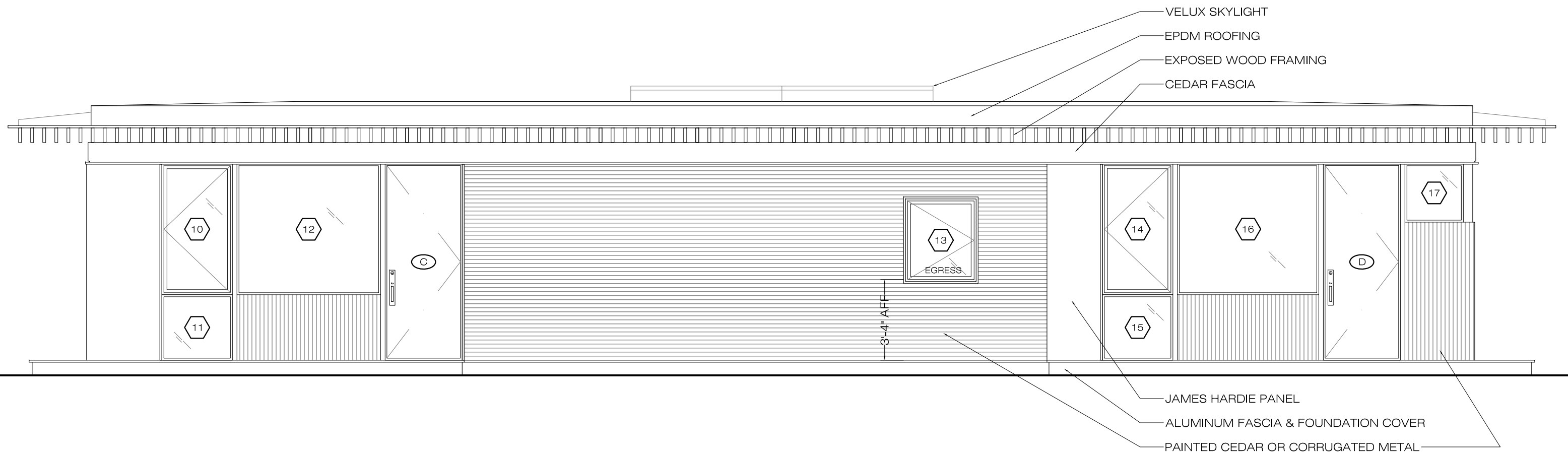

WINDOW SCHEDULE

#	WIDTH	HEIGHT	SERIES	HAND	DEPTH	TYPE	GLASS	MULL
01	41	29	Lifestyle	top	5	awning		factory mulld to 02
02	41	68.5	Lifestyle		5	fixed frame direct set	safety glazing	factory mulld to 01
03	65.25	29	Lifestyle		5	fixed frame direct set		
04	35	41	Lifestyle	right	5	casement	egress	
05	29	29	Lifestyle	top	5	awning		factory mulld to 06
06	29	68.5	Lifestyle		5	fixed frame direct set	safety glazing	factory mulld to 05
07	76.125	29	Lifestyle		5	fixed frame direct set		
08	29	29	Lifestyle		5	fixed frame direct set		
09	50.75	29	Lifestyle		5	fixed frame direct set		
10	35	65	Lifestyle	left	5	casement		factory mulld to 11
11	35	32.5	Lifestyle		5	fixed frame direct set		factory mulld to 10
12	71.25	65	Lifestyle		5	fixed frame direct set	safety glazing	
13	35	41	Lifestyle	right	5	casement	egress	
14	35	65	Lifestyle	left	5	casement		factory mulld to 15
15	35	32.5	Lifestyle		5	fixed frame direct set		factory mulld to 14
16	70.125	65	Lifestyle		5	fixed frame direct set	safety glazing	
17	29	29	Lifestyle		5	fixed frame direct set		
18	50.75	29	Lifestyle		5	fixed frame direct set		

- NOTES:**
- a. black exterior, bright white interior, white hardware
 - b. fixed frame to be direct set, interior glazed
 - c. awning glazing to be 11/16" advanced comfort low-e ig with a u factor of .26
 - d. casement glazing to be 11/16" advanced comfort low-e ig with a u factor of .25
 - e. fixed frame glazing to be 13/16" advanced comfort low-e ig with a u factor of .24

DOOR SCHEDULE

#	WIDTH	HEIGHT	SERIES	HAND	DEPTH	NOTES
A	38.25	97.94	Entry Door	RHR	4 9/16	solid panel flush out-swing smooth fiberglass, normal profile vent sill, santa cruz handle set in satin nickel, black finish aluminum sill
B	38.25	97.94	Entry Door	RHR	4 9/16	solid panel flush out-swing smooth fiberglass, normal profile vent sill, santa cruz handle set in satin nickel, black finish aluminum sill
C	38.25	97.94	Entry Door	RHR	4 9/16	solid panel flush out-swing smooth fiberglass, normal profile vent sill, santa cruz handle set in satin nickel, black finish aluminum sill
D	38.25	97.94	Entry Door	RHR	4 9/16	solid panel flush out-swing smooth fiberglass, normal profile vent sill, santa cruz handle set in satin nickel, black finish aluminum sill

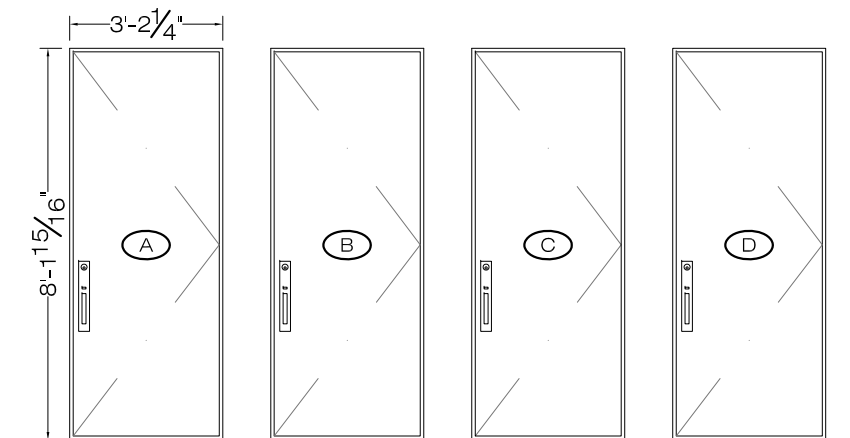
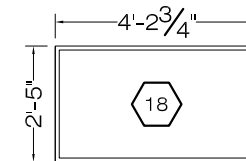
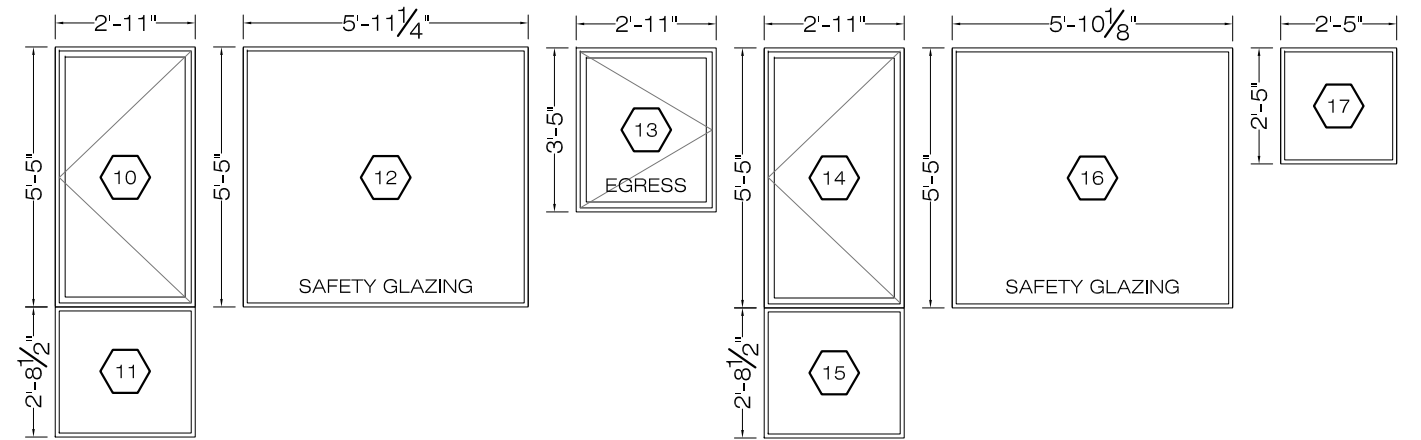
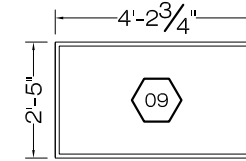
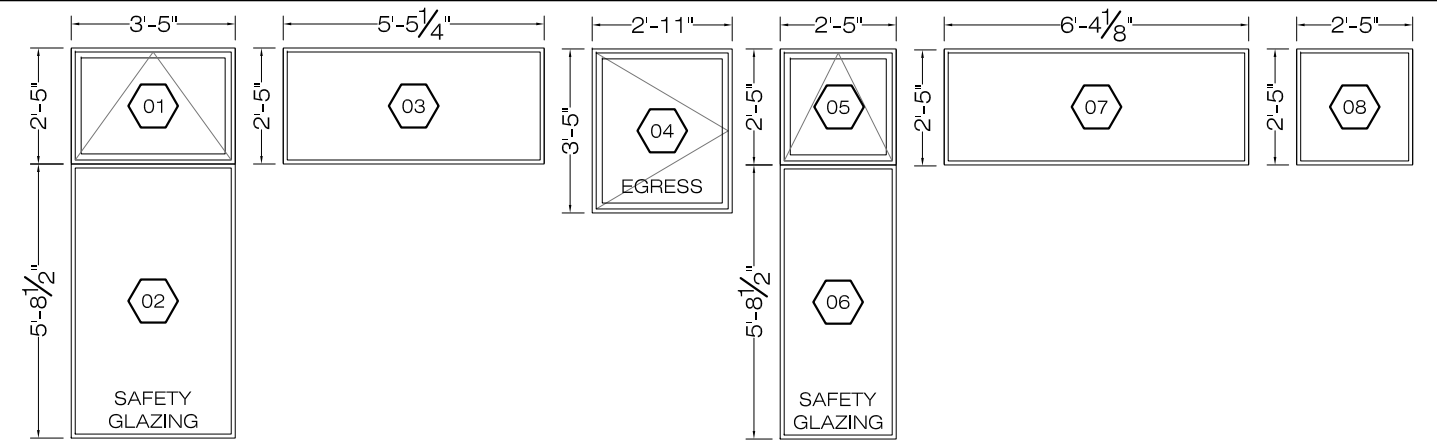

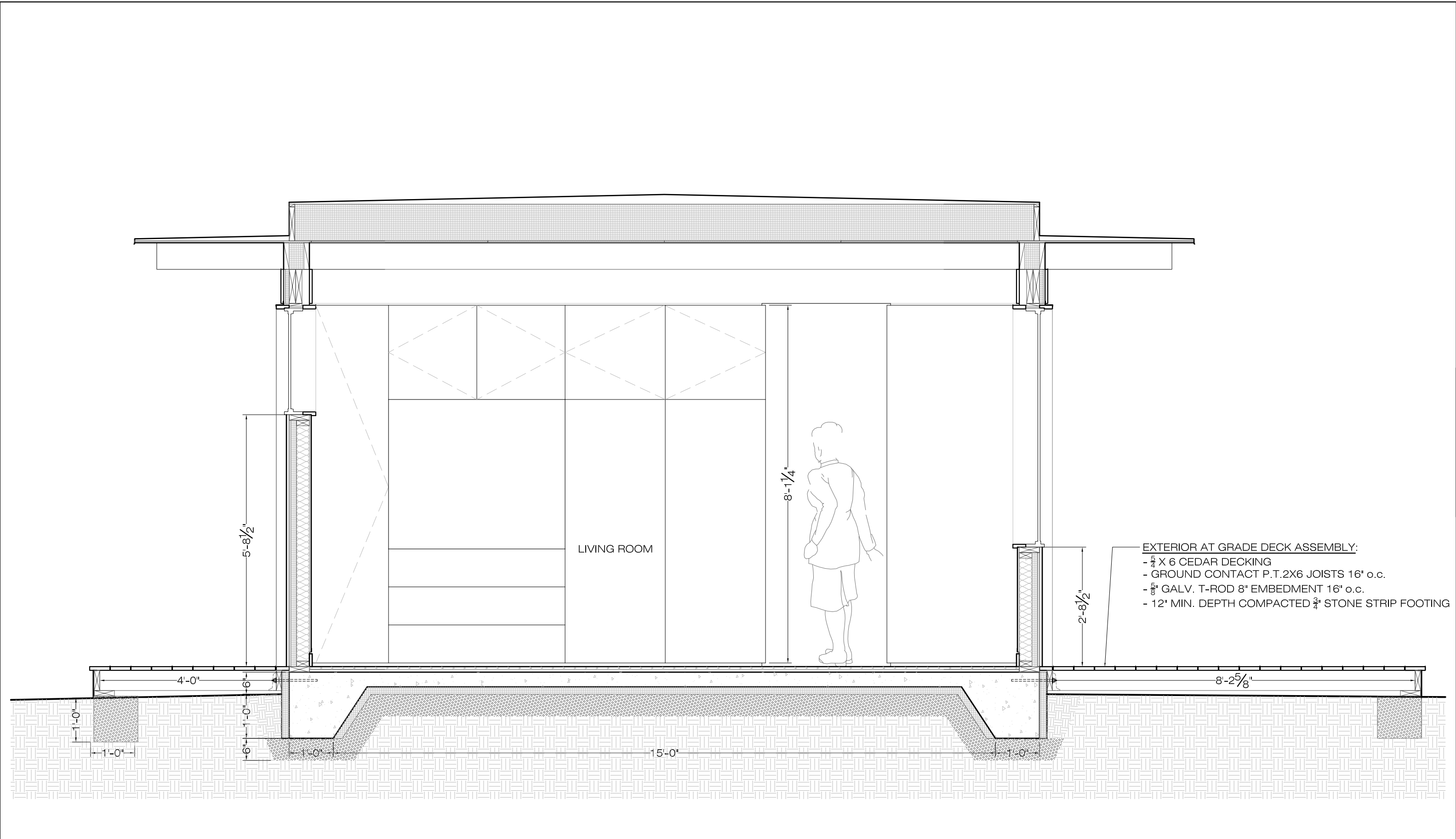

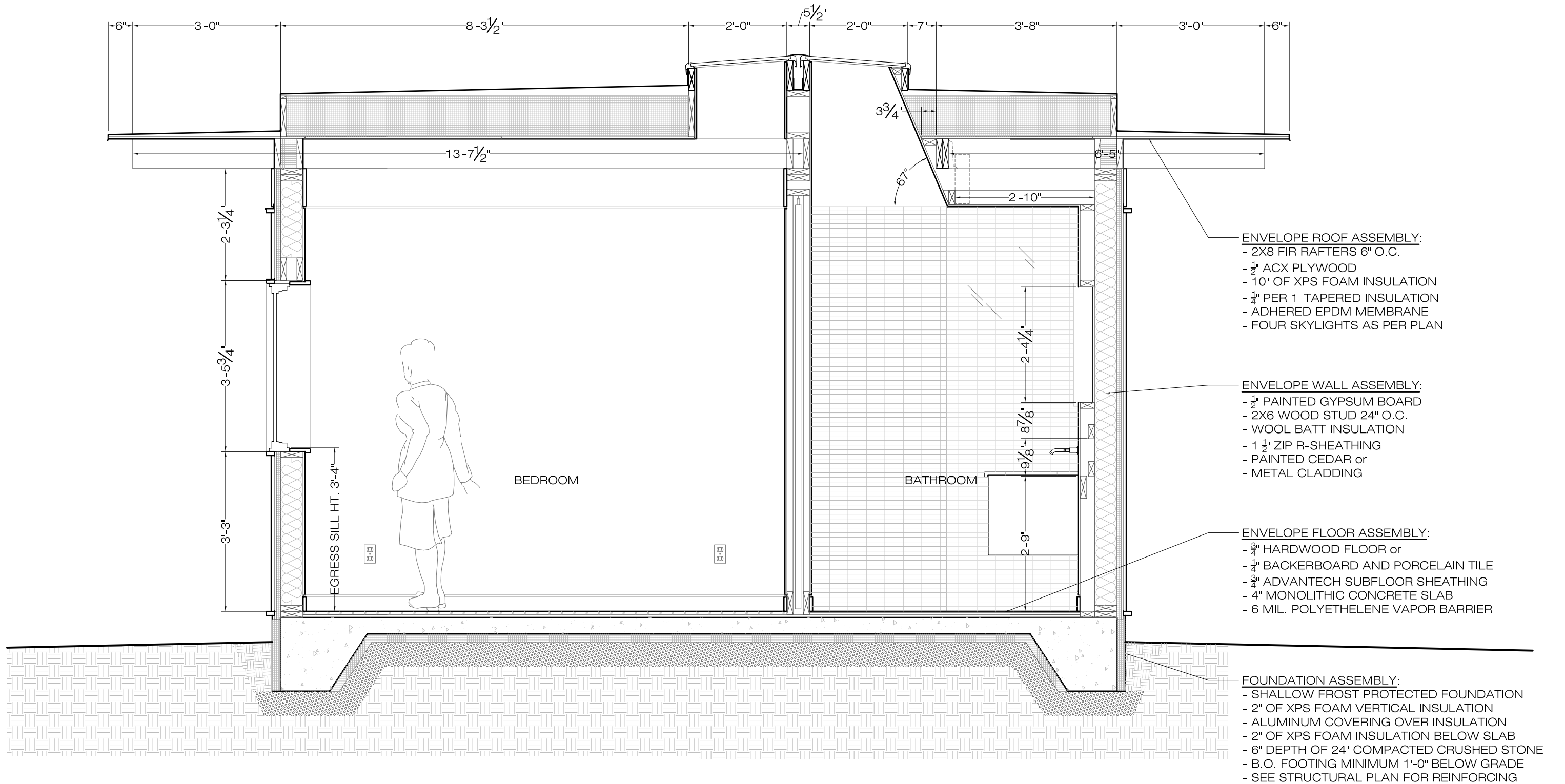

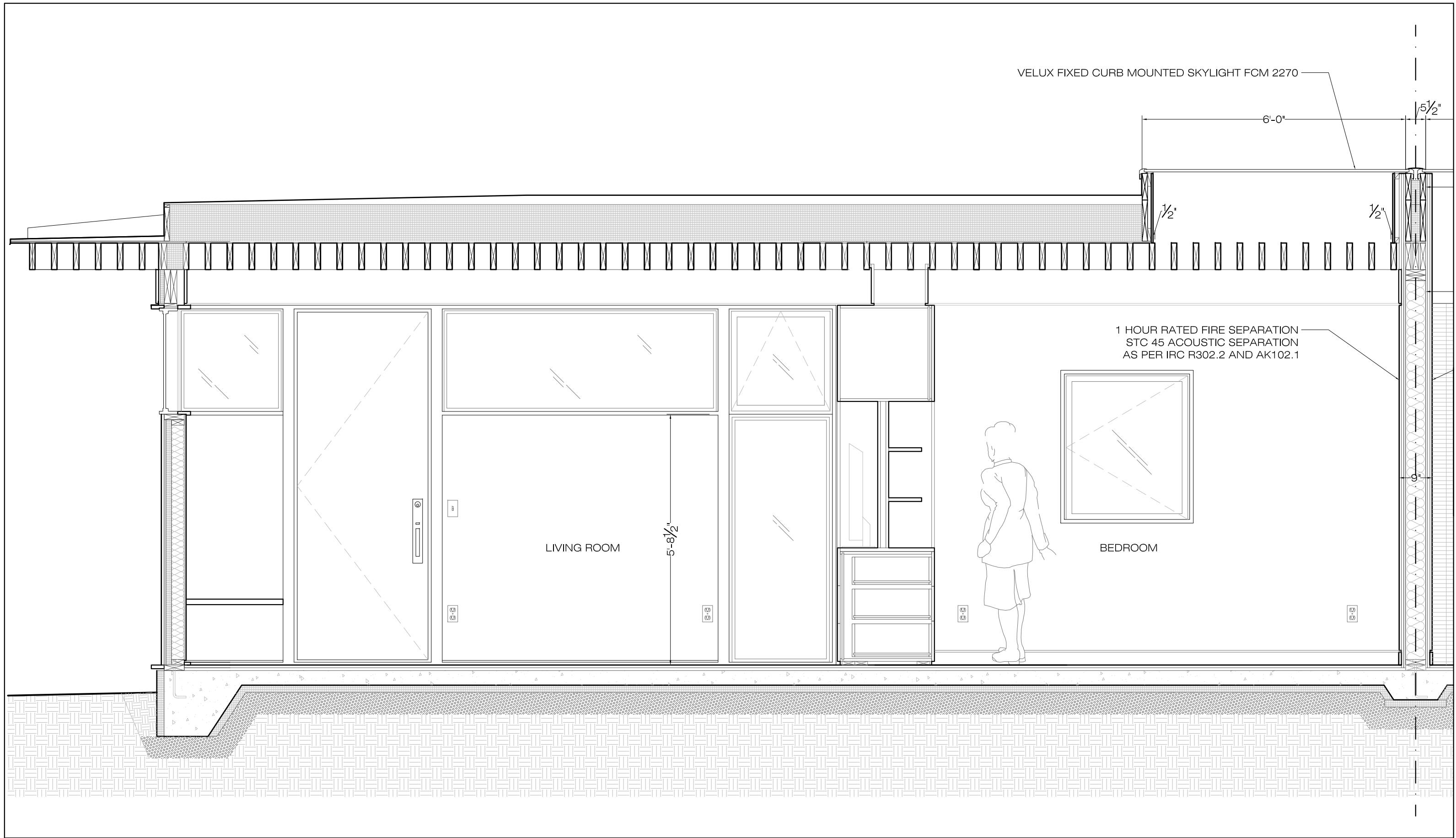



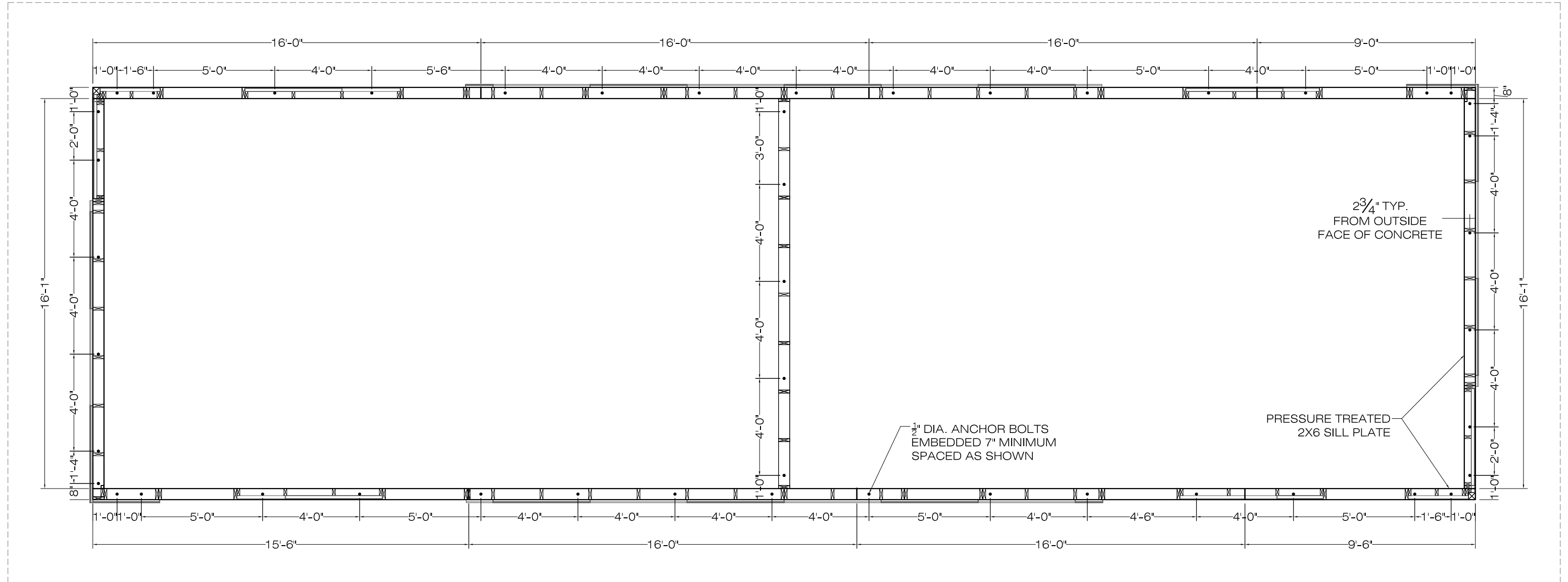
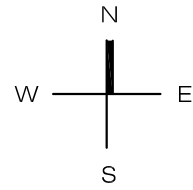

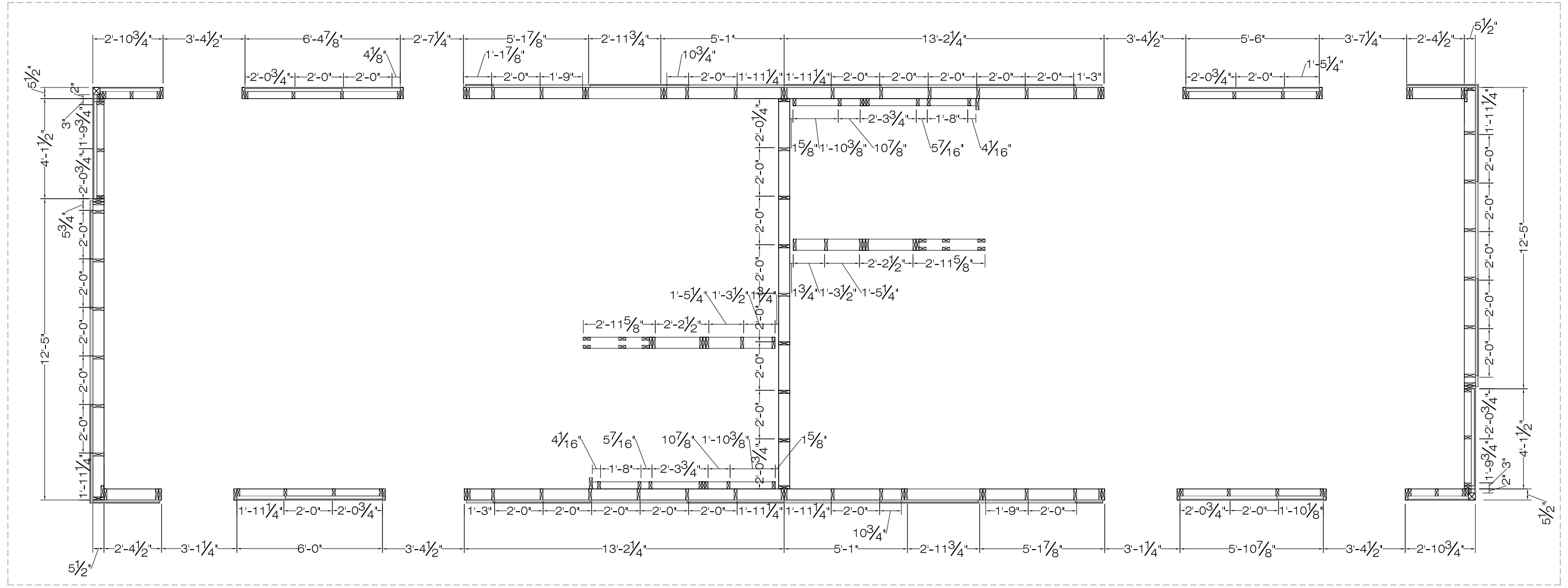
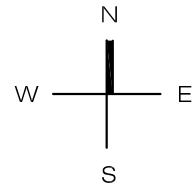

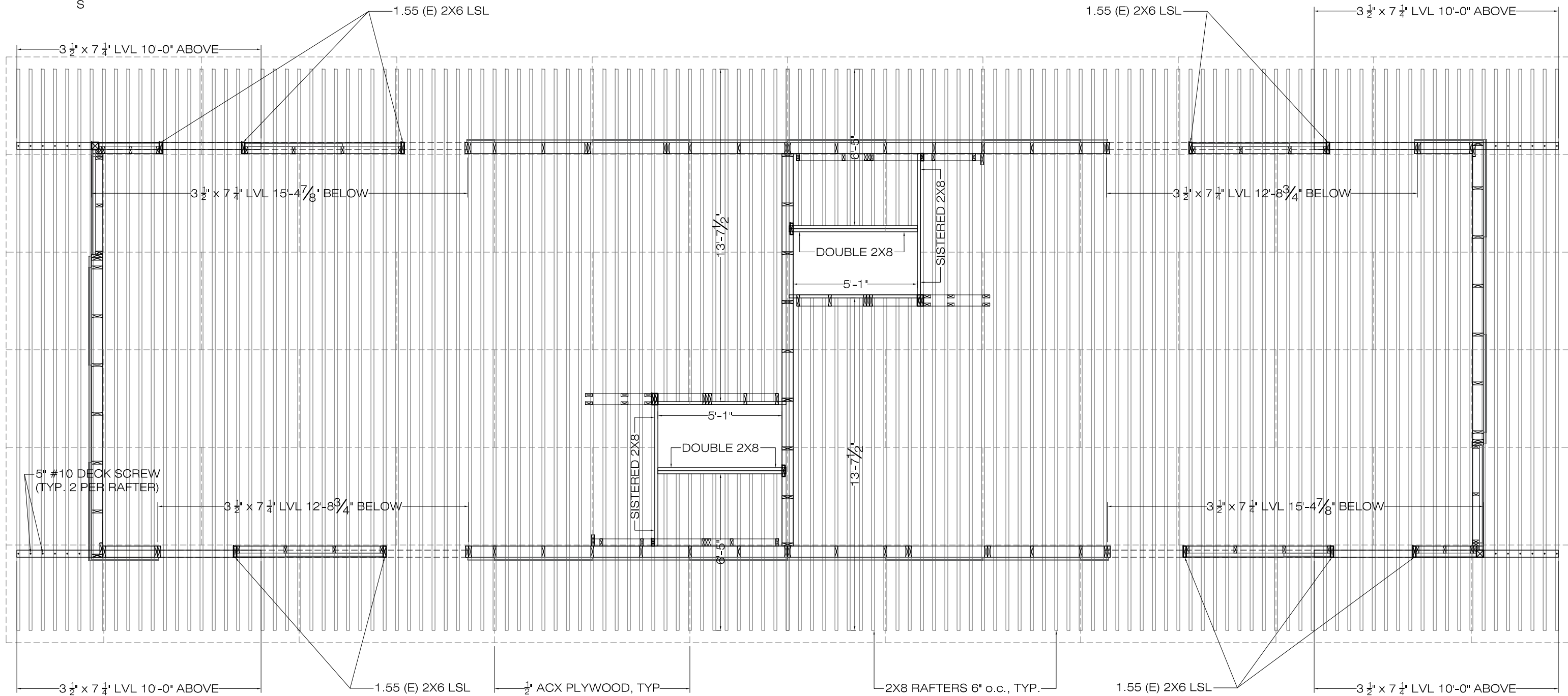
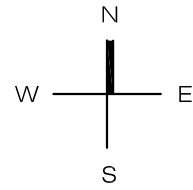

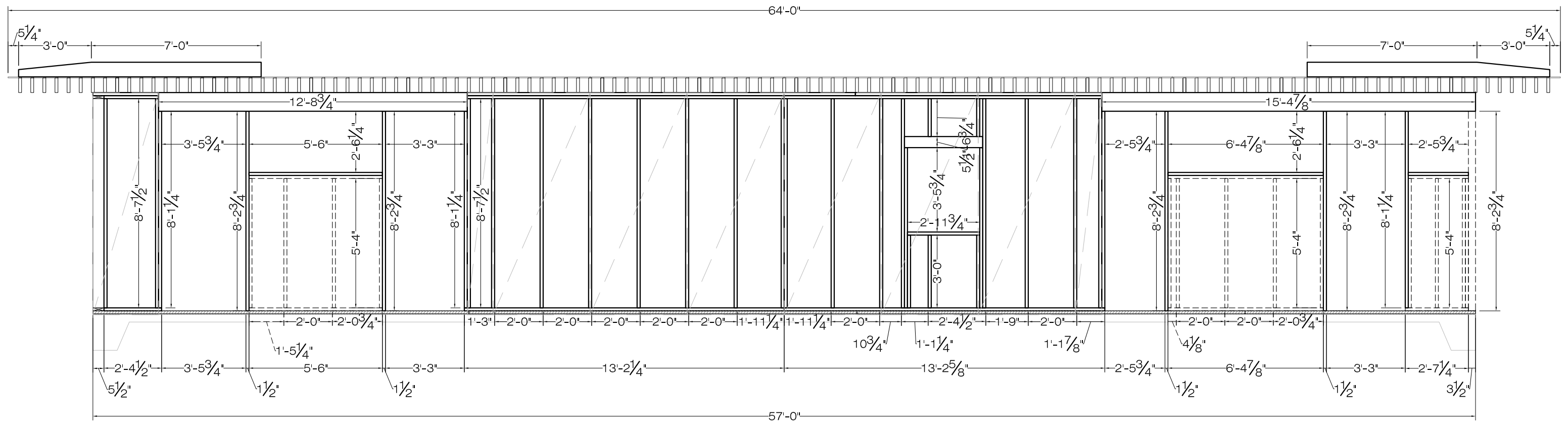

===== 2X4 FRAMING
 ===== 2X6 P.T. SILL PLATE

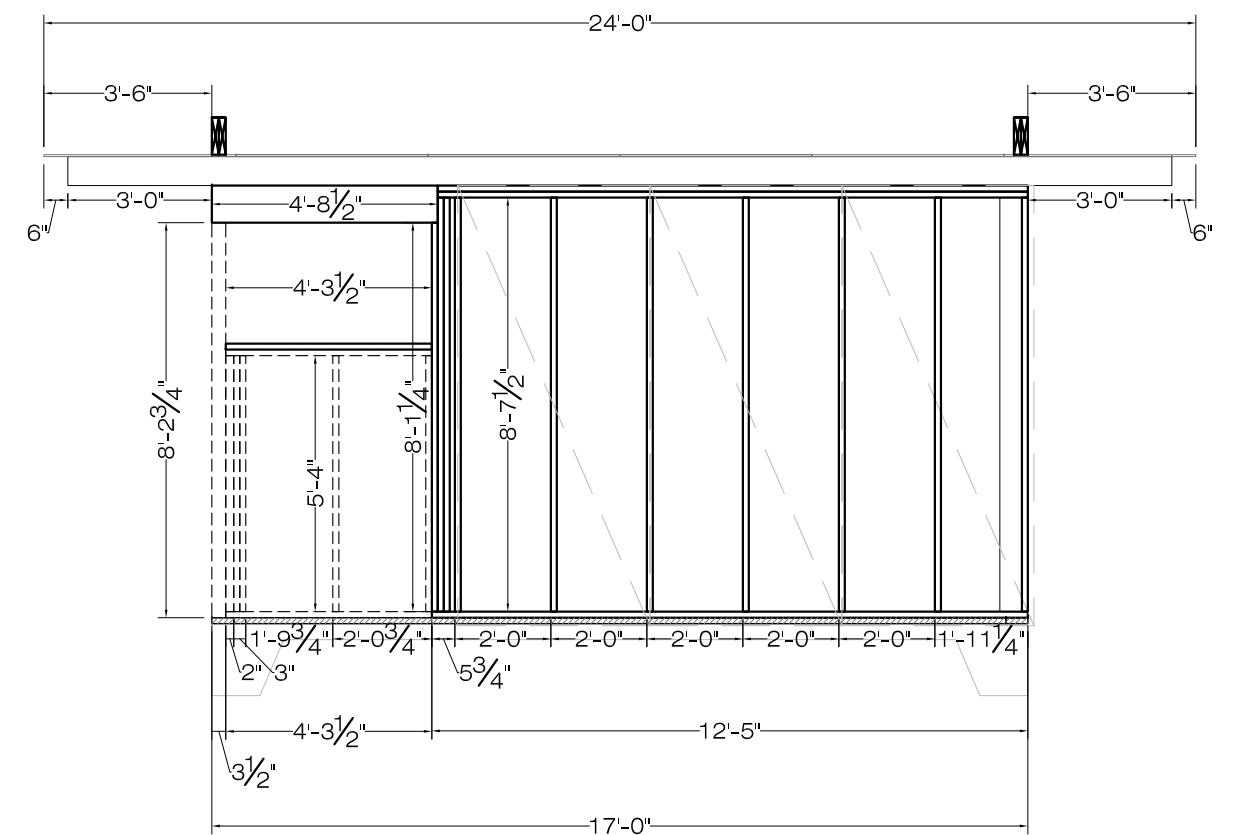
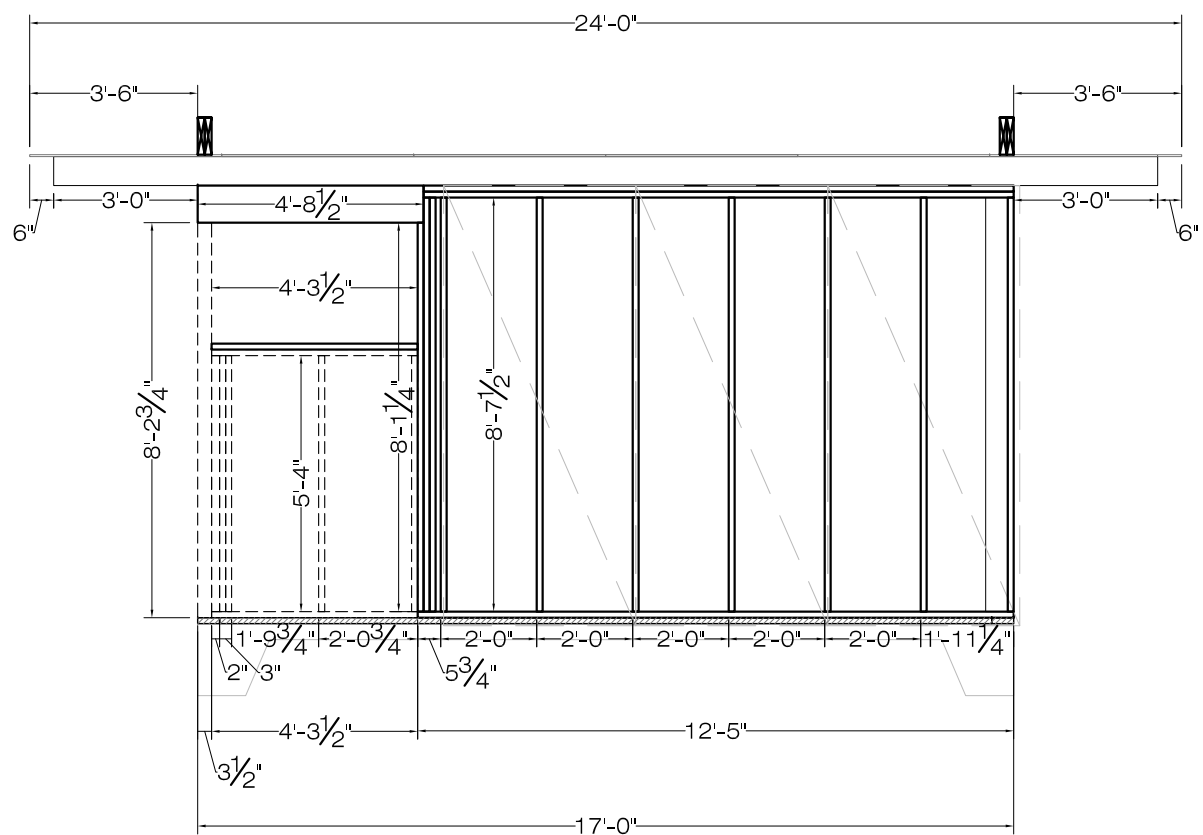

----- 2X4 FRAMING
 ===== 2X6 P.T. SILL PLATE

WEST ELEVATION

EAST ELEVATION

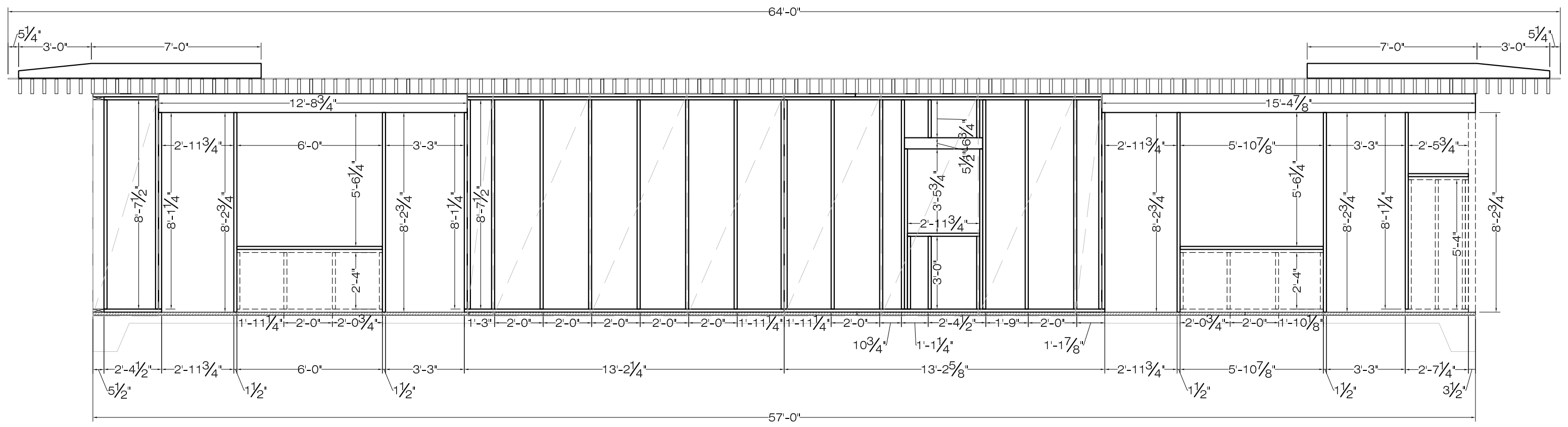

----- 2X4 FRAMING
 ===== 2X6 P.T. SILL PLATE

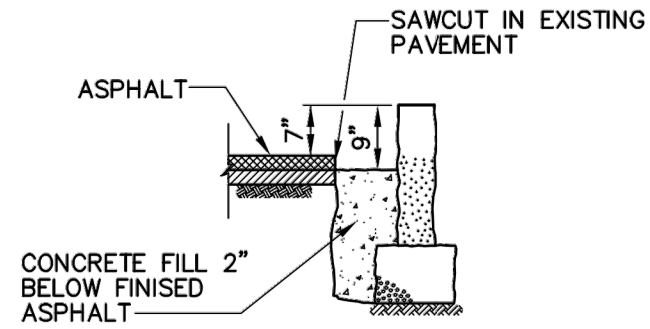

CROSS SECTION
CURB AT STREET CUT
SCALE: 1/2"=1'-0"

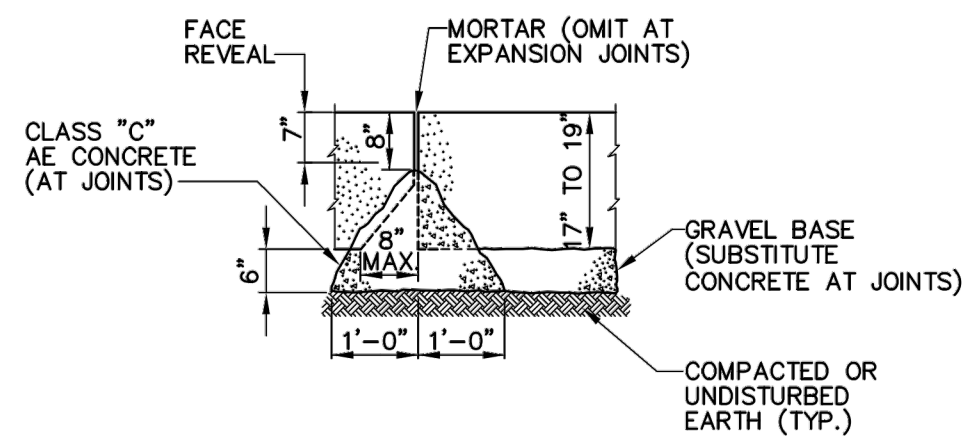
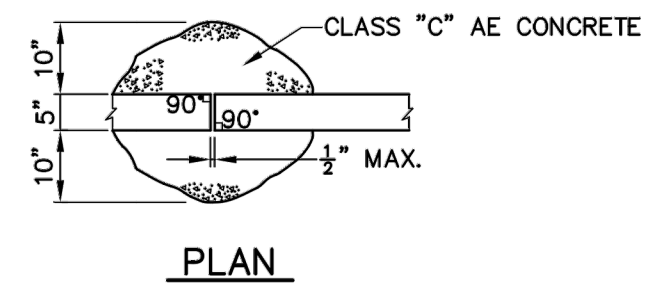

PARTIAL ELEVATION

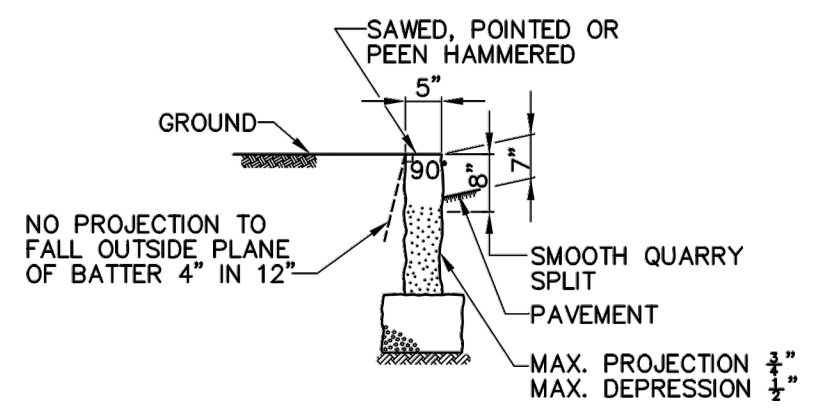

CROSS SECTION
GRANITE CURB DETAIL
SCALE: 1/2"=1'-0"

NOTES:

1. ALL PIECES SHALL BE 6'-0" LONG EXCEPT FOR CLOSURES WHERE NO PIECE LESS THAN 4'-0" LONG SHALL BE USED.
2. CURBS OF RADIUS LESS THAN 100' SHALL BE CUT OR CAST TO REQUIRED RADIUS AND LENGTH.
3. USE 1/2" PREFORMED EXPANSION JOINT FILLER SPACED NOT MORE THAN 20'-0" O.C. FOR PRECAST OR CAST-IN-PLACE CONCRETE CURB.
4. JOINT BETWEEN GRANITE OR CONCRETE SECTIONS ARE NOT TO EXCEED 1/2".
5. MINIMUM WIDTH OF CURB AT BOTTOM SHALL BE 4" OR NO GREATER THAN 2/3 THE HEIGHT OF THE PIECE.
6. CLASS "C" AE CONCRETE TO BE PLACED AT JOINTS AS SHOWN IN GRANITE CURB DETAIL, AND ALONG STREET TRENCH AS SHOWN IN DETAIL.

MATERIALS:

1. STONE FOR GRANITE CURBING SHALL BE HARD AND DURABLE GRANITE OF LIGHT COLOR AND UNIFORM TEXTURE, NEITHER STRATIFIED NOR LAMINATED. IT SHALL BE FREE FROM SEAMS AND EVIDENCE OF WEAKENING OR DISINTEGRATION AND SHALL HAVE GOOD, SMOOTH SPLIT FACES.
2. THE TOP SURFACE SHALL BE POINTED, PEEN HAMMERED AND SAWED. THE TOP 8 INCHES OF THE FACE SHALL BE SMOOTH QUARRY SPLIT AND FREE FROM DRILL HOLES. THE ENDS OF ALL STONES SHALL BE SQUARE WITH THE PLANES OF THE TOP AND FACE, AND SO FINISHED THAT WHEN STONES ARE PLACED END TO END AS CLOSELY AS POSSIBLE, NO SPACE MORE THAN 1/8 INCH SHALL SHOW IN THE JOINT FOR THE FULL WIDTH OF THE TOP OR THE TOP 8 INCHES OF THE FACE. THE TOP STREET SIDE FACE OF THE CURB SHALL NOT HAVE SHARP EDGES.

****NOTE:**

TO BE USED ONLY IN AREAS AS APPROVED BY THE CITY ENGINEER.

TACK ALL BITUMINOUS CURBING
 (RECEIVING SURFACE SHALL BE
 CLEANED OF SAND AND SILT
 DEBRIS BEFORE APPLYING)

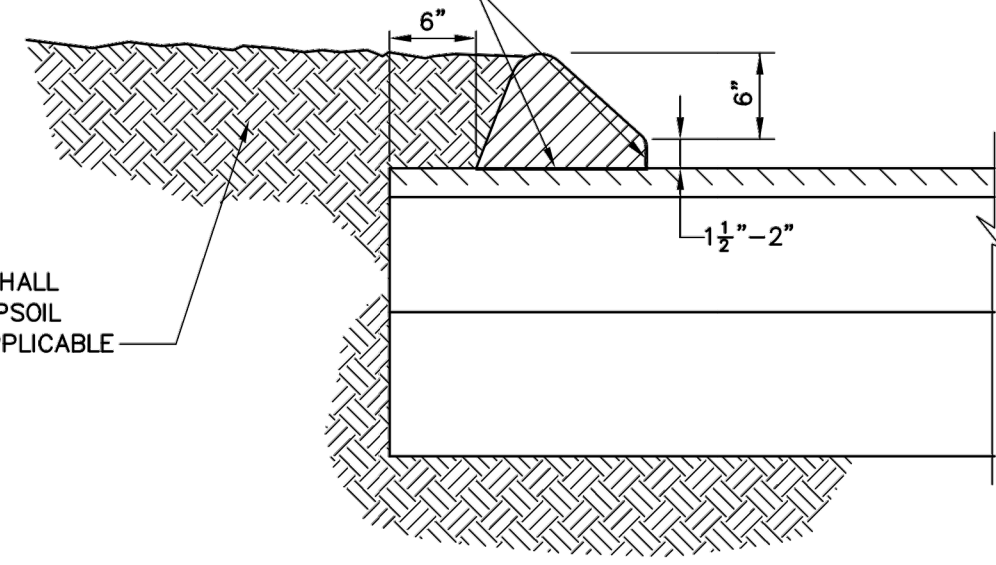

ALL BITUMINOUS SHALL
 BE BACK WITH TOPSOIL
 OR GRAVEL AS APPLICABLE

CURB ON EXISTING ROAD

TACK ALL BITUMINOUS CURBING
 (RECEIVING SURFACE SHALL BE
 CLEANED OF SAND AND SILT
 DEBRIS BEFORE APPLYING)

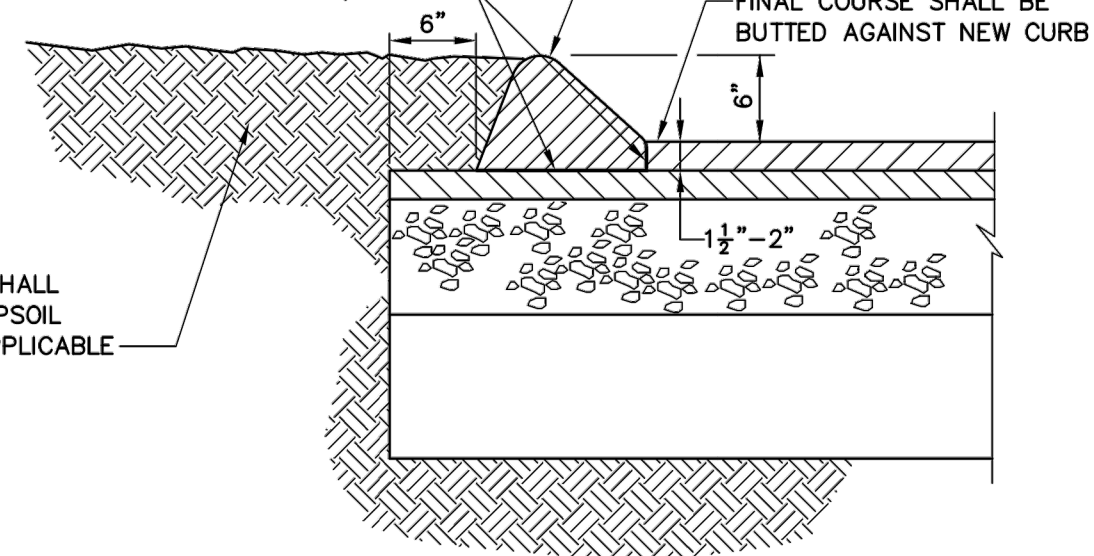

ALL BITUMINOUS SHALL
 BE BACK WITH TOPSOIL
 OR GRAVEL AS APPLICABLE

BITUMINOUS CONCRETE LIP CURBING

SCALE : 1"=1'-0"

NOTE: WHERE BIT. CURB IS OVERLAID ON EXISTING
 PAVEMENT, SETBACK OF PAVEMENT; LAY CURBLINE
 STRAIGHT AND PROVIDE SMOOTH TRANSITIONS.

****NOTE:**
 TO BE USED ONLY IN AREAS AS APPROVED BY THE CITY ENGINEER.

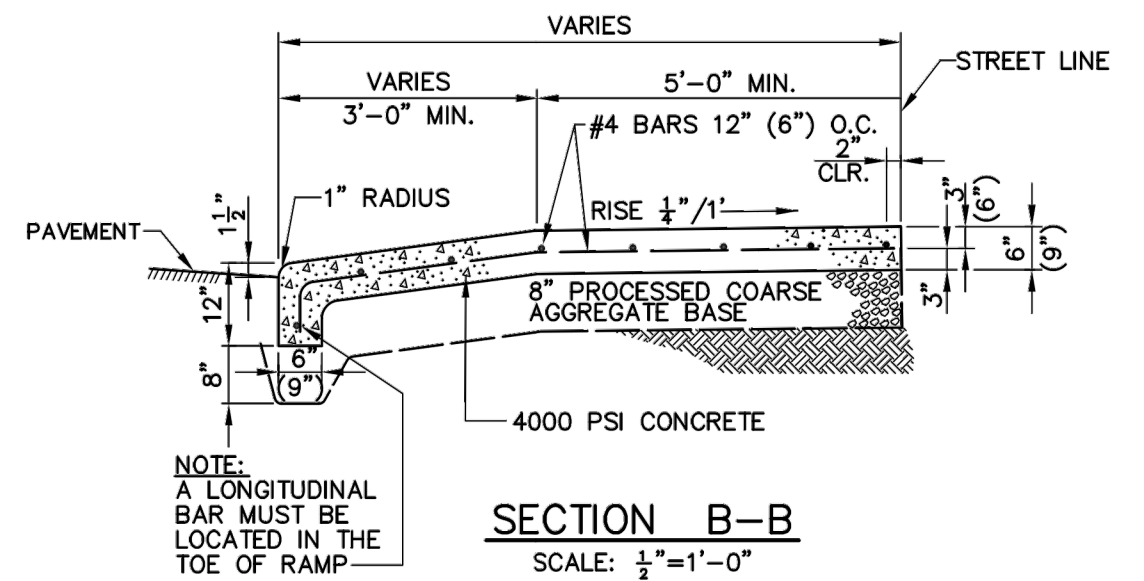
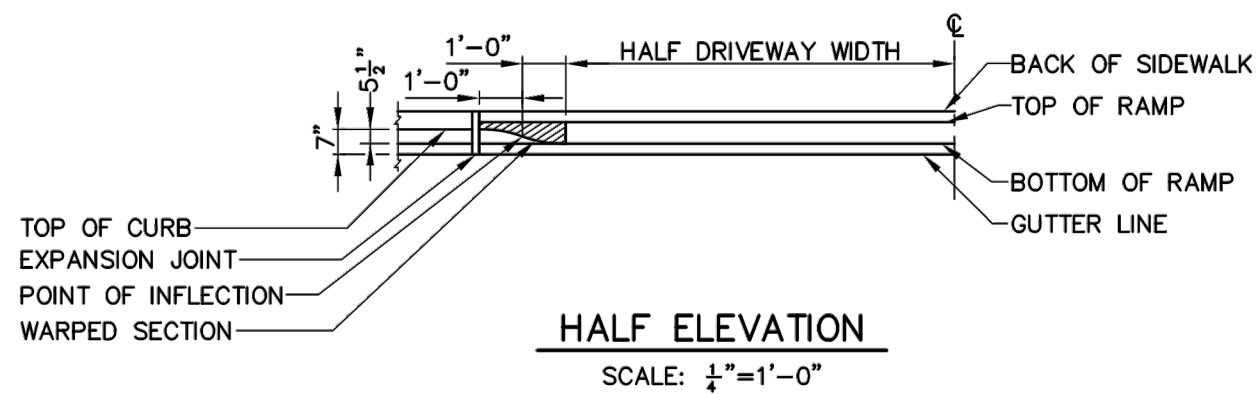
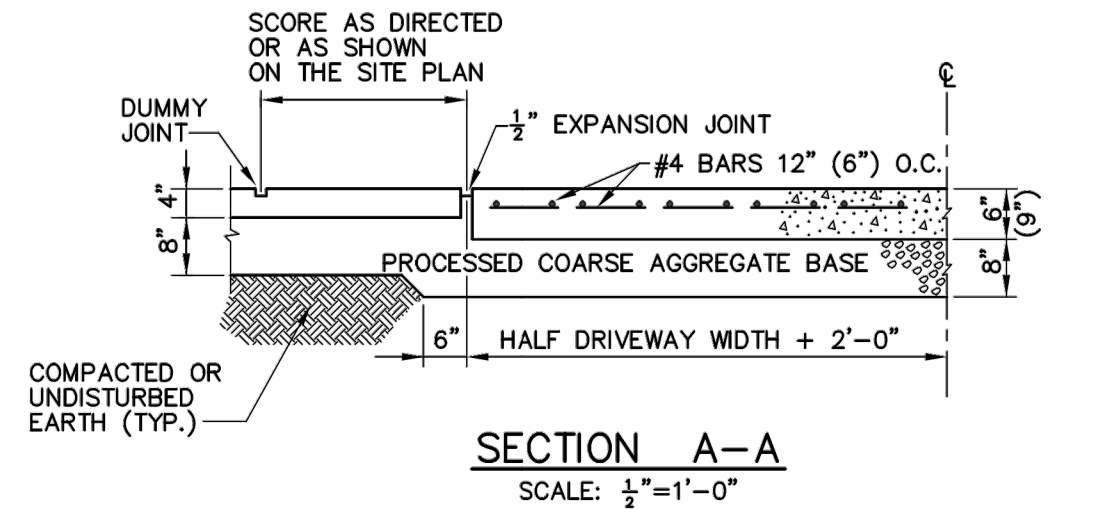
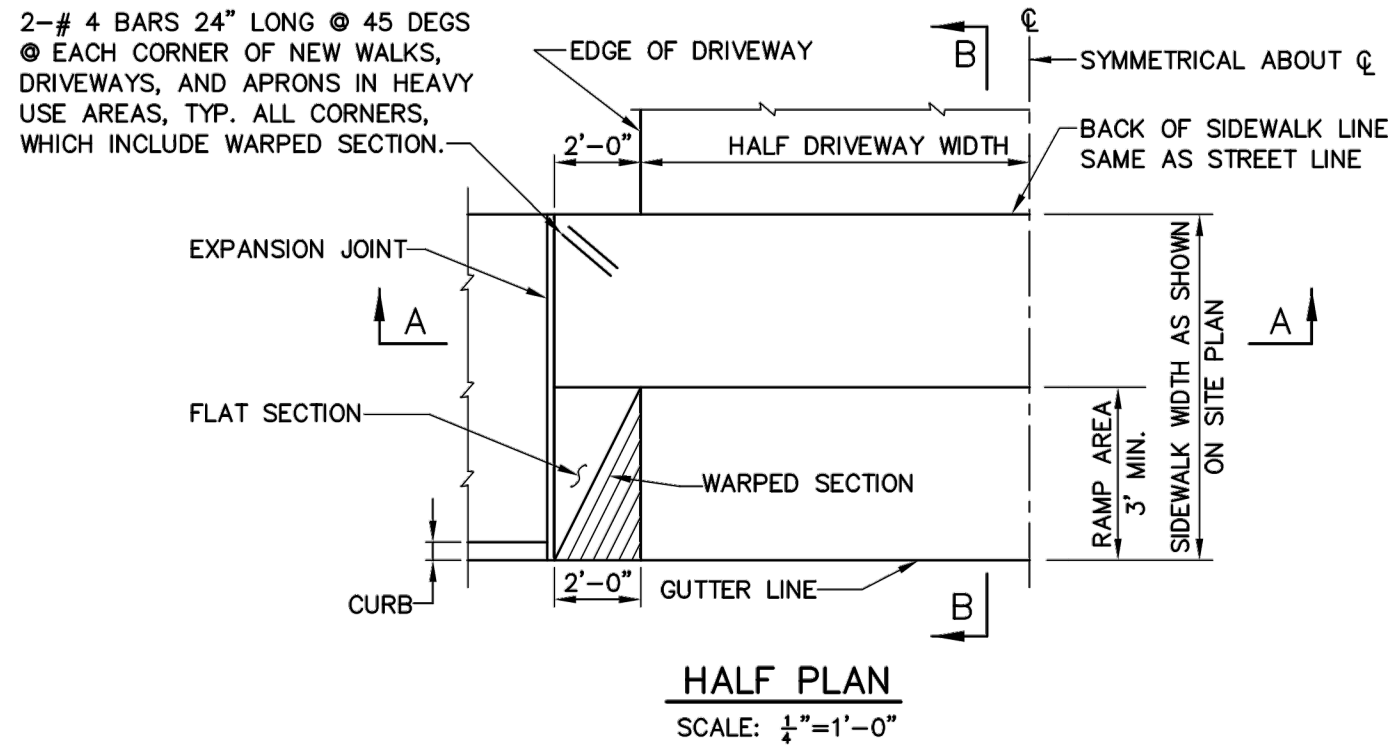

TYPICAL CONCRETE DRIVEWAY DETAILS
AS SHOWN

NOTE: THE NUMBERS IN PARENTHESES APPLY ONLY TO
COMMERCIAL DRIVEWAYS

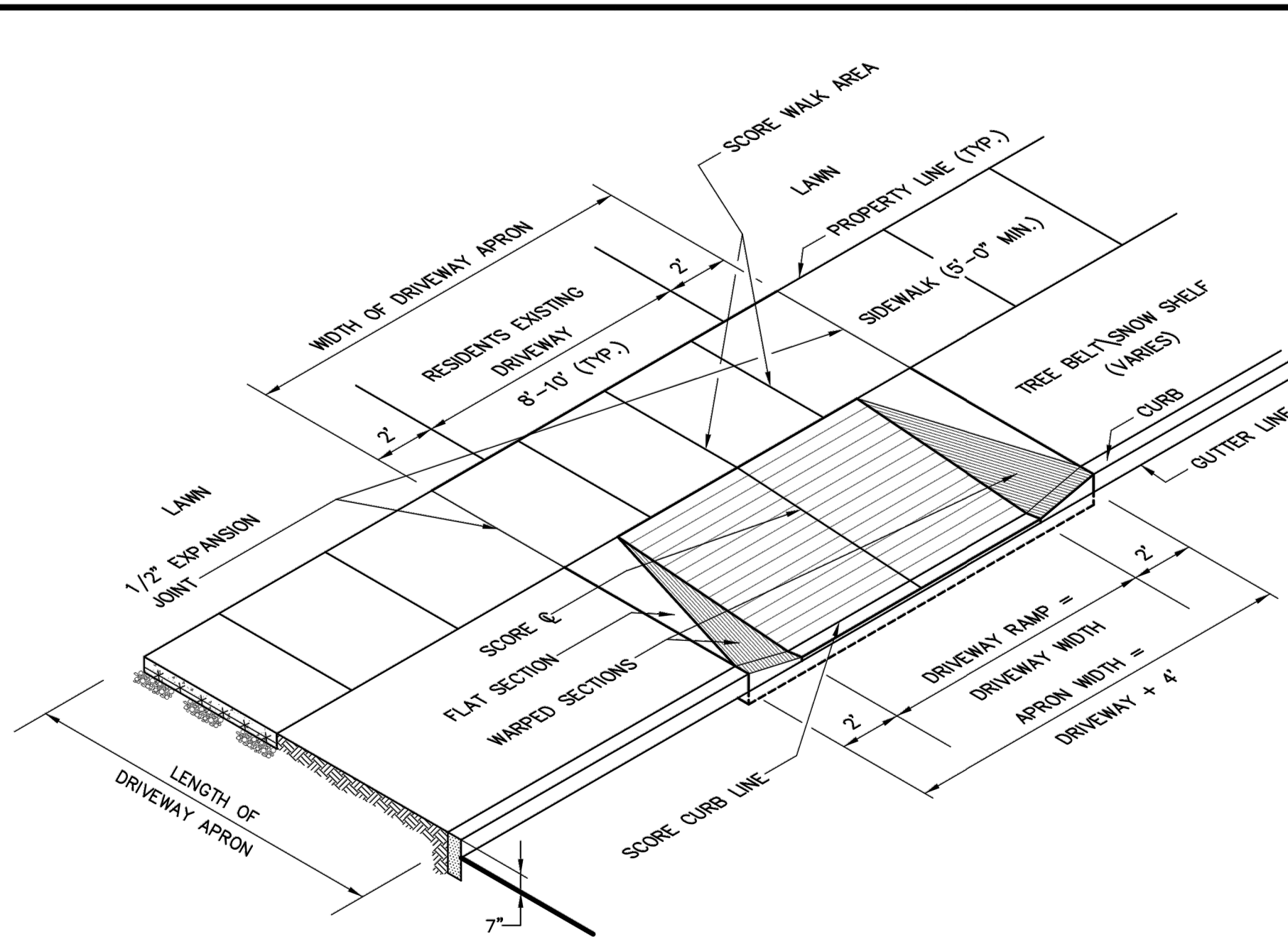

TYPICAL CONCRETE DRIVEWAY RAMP (ISOMETRIC VIEW)

SCALE: 1/4" = 1'-0"

NOTE:
FIELD ADJUSTMENTS MAY BE REQUIRED FOR UNUSUAL EXISTING FEATURES SUCH AS TREES, POWER POLES, ETC.

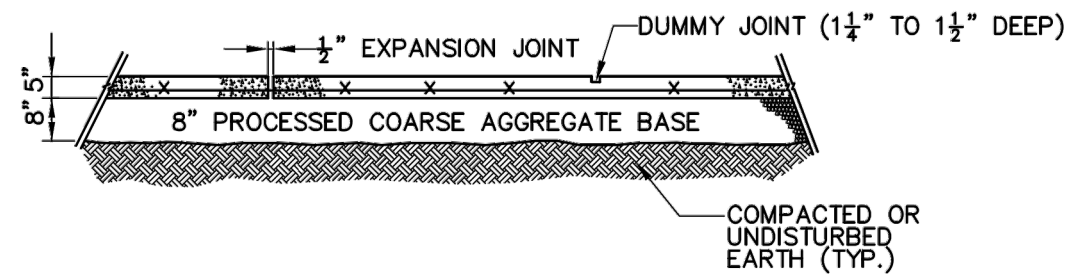

SECTION C-C
SCALE $\frac{3}{8}'' = 1'-0''$

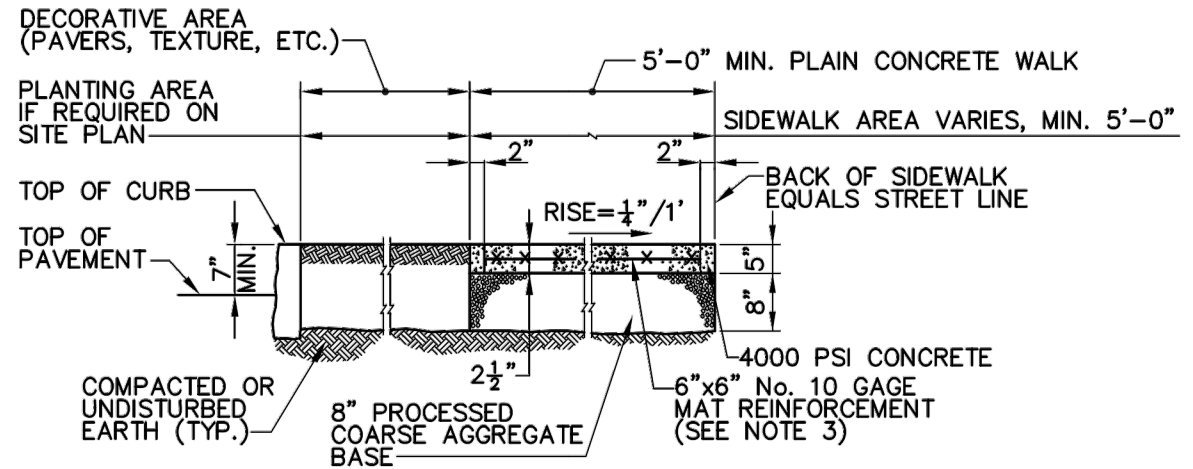

SECTION D-D
SCALE $\frac{1}{2}'' = 1'-0''$

NOTES:

1. MATERIALS, METHODS OF INSTALLATION, CURING, TESTING, SHALL CONFORM TO "STATE OF CT DEPARTMENT OF TRANSPORTATION STANDARD SPECIFICATIONS FORM 814A, OR 815 © 1995 OR CURRENT SPECIFICATION FOR SUCH WORK.
2. ANY WALKING SURFACE SHALL BE LIGHTLY BROOMED PERPENDICULAR TO THE TRAVEL WAY.
3. WIRE MESH SHALL BE PLACED 2 1/2" BELOW THE SIDEWALK SURFACE. MATERIAL SHALL BE 6 "x 6" NO. 10 GAGE AND IN ACCORDANCE WITH ASTM 185 (AASHTO M55),AS SHOWN ON THE PLANS OR AS DIRECTED. WIRE MESH TO BE USED IN ALL COMMERCIAL SIDEWALK APPLICATIONS. MESH MAY BE OMITTED ONLY WITH THE SPECIFIC AUTHORIZATION OF THE CITY ENGINEER ON A CASE-BY-CASE BASIS.

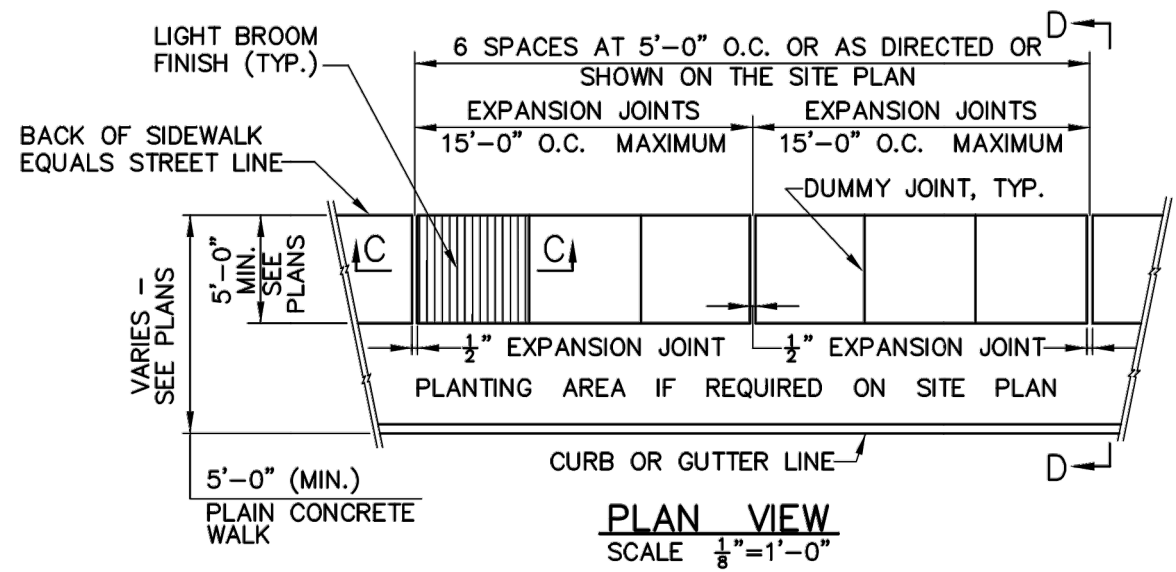

PLAN VIEW
SCALE $\frac{1}{8}'' = 1'-0''$

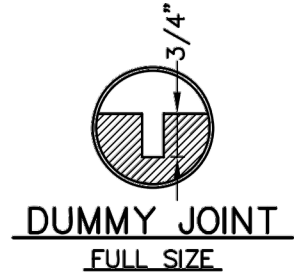

- SIDEWALK NOTES:**
1. UNLESS OTHERWISE SPECIFIED OR DIRECTED BACK OF WALK TO BE ON STREET LINE

TYPICAL SIDEWALK DETAILS
SCALE : AS NOTED

TREE PROTECTION NOTES:

1. BEFORE BEGINNING ANY SITE REMOVALS OR CONSTRUCTION, TREE PROTECTION FENCING SHALL BE INSTALLED AS SHOWN AND DETAILED ON THE DRAWINGS AND/OR AS DIRECTED IN THE FIELD BY THE ENGINEER. FOLLOWING THE INSTALLATION OF TREE PROTECTION FENCING AND FOR THE ENTIRE CONSTRUCTION PERIOD THE FOLLOWING SHALL APPLY:
 - NO MATERIALS, VEHICLES OR EQUIPMENT MAY BE STORED OR STOCKPILED WITHIN THE AREAS ENCLOSED BY TREE PROTECTION FENCING.
 - NO VEHICLES OR EQUIPMENT MAY BE DRIVEN, OPERATED OR PARKED WITHIN AREAS ENCLOSED BY TREE PROTECTION.
 - AREAS ENCLOSED BY TREE PROTECTION CAN NOT BE USED AS ROUTES FOR SITE TRAFFIC
 - FENCING SHALL BE RESECURED AS NECESSARY AND MAINTAINED TAUT. FENCING SHALL BE REPAIRED OR REPLACED WHEN DAMAGED AT NO ADDITIONAL COST.
 - IN SPECIAL CASES WHERE CONSTRUCTION OPERATIONS ABSOLUTELY REQUIRE SOME TEMPORARY ENCROACHMENT INTO TREE PROTECTION AREAS, THE CONTRACTOR SHALL PRESENT A WORK PLAN FOR TEMPORARY ENCROACHMENT FOR THE ENGINEER'S APPROVAL.

2. ALL EXCAVATION OR TRENCHING WITHIN THE AREAS OF EXISTING TREE ROOTS SHALL BE CARRIED OUT BY HAND.
 - ROOTS IN TRENCH SHALL BE CUT SMOOTH AND CLEAN USING SHARP TOOLS. NO RIPPING OF TREE ROOTS BY MACHINES IS PERMITTED.
 - NO JAGGED EDGES OF ROOTS SHALL BE PERMITTED.
 - SIDES OF EXCAVATIONS SHALL BE CLEAN AND STRAIGHT.
 - IMMEDIATELY FOLLOWING TRENCHING OR EXCAVATION OPERATIONS, AREAS AT TREE ROOTS SHALL BE BACKFILLED.
 - ROOTS SHALL NOT BE LEFT EXPOSED OVERNIGHT.
 - BACKFILL SHALL BE A MIX OF 50% TOPSOIL AND 50% CLEAN SAND.
 - BACKFILL SHALL BE HAND COMPACTED IN PLACE TO FILL ALL VOIDS.

3. EXTREME CARE SHALL BE TAKEN TO AVOID ANY DAMAGE TO TRUNKS, BRANCHES AND ROOTS. ANY DAMAGE CAUSED TO TREES SHALL BE IMMEDIATELY REMEDIED BY THE CONTRACTOR.
 - REMEDIAL WORK MAY INCLUDE PRUNING, WOUND TREATMENT, CABLING OR ADDITIONAL MEASURES AS DETERMINED BY THE ENGINEER.
 - CONTRACTOR SHALL ENGAGE A LICENSED ARBORIST TO PERFORM ALL WORK AT NO ADDITIONAL COST TO THE OWNER.

4. THE CONTRACTOR SHALL REVIEW ALL PLANNED CONSTRUCTION OPERATIONS THAT MAY RESULT IN TREE DAMAGE FOR REVIEW AND APPROVAL BY THE ENGINEER.
 - SPECIAL ATTENTION SHALL BE MADE TO THE PATH OF PLACING CONSTRUCTION MATERIAL ON SITE BY CRANE.
 - THE CONTRACTOR SHALL PRESENT A WORK PLAN AND PROPOSED TREE PROTECTION MEASURES TO MINIMIZE DAMAGE TO TREES.

TREE PROTECTION NOTES

SCALE: NONE

**CITY OF NEW HAVEN
DEPARTMENT OF ENGINEERING**

RICHARD H. MILLER, P.E., L.S. 9886
CITY ENGINEER

DRIVE: K:\ENGINEER\DWG
FILE: CITYSTD\DETAILS\2009 DETAILS
DATE: DEC. 1, 2009
DRAWING NO.:
STD-NH-32C

TREES SUITIBLE FOR PLANTING IN THE TREE BELT		
SPECIES	VARIETIES PERMITTED	VARIETIES PROHIBITED
ACER RUBRUM (RED MAPLE)	OCTOBER GLORY RED SUNSET COLUMNAR VARIETIES COLUMNAR VARIETIES	SILVER MAPLE NORWAY MAPLE
ACER SACCHARUM (SUGAR MAPLE)	GREEN MOUNTAIN	
CARPINUS BETULUS/ FASTIGIATA 'COLUMNARIS' (EUROPEAN HORNBEAM)	FASTIGATE	
PYRUS CALLERYANA (CALLERY PEAR)	CHANTICLEER ARISTOCRAT REDSPIRE	BRADFORD
TILIA CORDATA (LITTLELEAF LINDEN)	GREENSPIRE SALEM	
ZELKOVA SERRATA (JAPANESE ZELKOVA)	VILLAGE GREEN GREEN VASE	
GLEDITSIA TRIACANTHOS INERMIS (THORNLESS HONEY LOCUST)	SUNBURST SHADEMASTER MAJESTIC SKYLINE	ANY VARIETY THAT HAS SEED PODS OR THORNS. LONDON PLANETREE SYCAMORE
ROBINA PSEUDOACACIA (BLACK LOCUST)	PYRAMIDALIS BESSONIANA	ANY VARIETY THAT HAS SEED PODS OR THORNS.
FRAXINUS PENNSYLVANICA (GREEN ASH)	MARSHALL'S SEEDLESS NEWPORT PATMORE	
QUERCUS PALUSTRIS (PIN OAK)		

TREES SUITIBLE FOR PLANTING UNDER UTILITY WIRES		
SPECIES	VARIETIES PERMITTED	VARIETIES PROHIBITED
ACER BUERGERANUM (TRIDENT MAPLE)		
ACER CAMPESTRE (HEDGE MAPLE)		
PRUNUS SERRULATA 'KWANZAN' (KWANZANN CHERRY)		
PRUNUS SARGENTII (COLUMNAR SARGENT CHERRY)	COLUMNARIS ACCOLADE	
SYRINGA RETICULATA (JAPANESE TREE LILAC)	IVORY SILK REGENT SUMMER SNOW	

RECOMMENDED TREE TYPES

SCALE: NONE

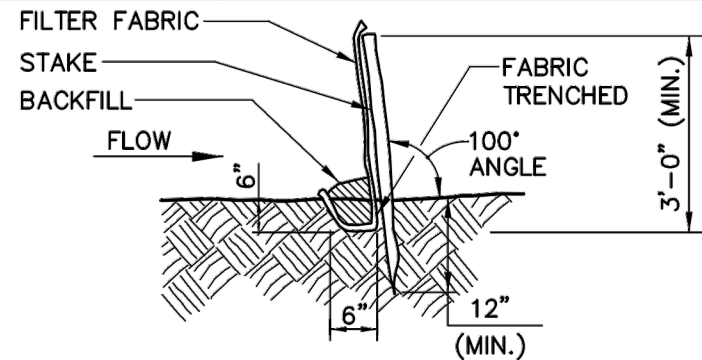

SILT FENCE INSTALLATION

- A) MINIMUM LENGTH OF SILT FENCE IS 15 L.F.
- B) MAXIMUM POST SPACING IS 10 L.F.
- C) JOINTS ONLY AT SUPPORT POST WITH MINIMUM 6" OVERLAP, SECURELY SEALED.
- D) SEDIMENTATION DEPOSITS SHALL BE REMOVED WHEN THEY REACH 1/2 THE HEIGHT OF THE SILT FENCE.
- E) SILT FENCE SHALL NOT BE USED IN A WATER COURSE.
- F) UPON ESTABLISHMENT OF GROUND COVER ON DISTURBED AREAS, AND WHEN DIRECTED BY THE ENGINEER, FENCE WILL BE REMOVED AND ANY SEDIMENTATION WILL BE THINLY SPREAD UPON EXISTING GROUND COVER.

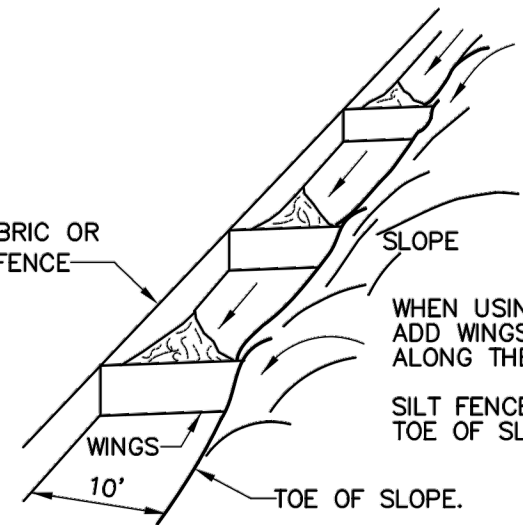

WHEN USING SILT FENCE ALONG TOE OF SLOPE, ADD WINGS TO PREVENT SEDIMENT FROM MOVING ALONG THE FENCE AND OFF THE SITE.
SILT FENCE SHOULD BE LOCATED 10' FROM TOE OF SLOPE.

**SEDIMENTATION CONTROL SYSTEM
TOE OF SLOPE**

WHERE DIRECTED BY ENGINEER

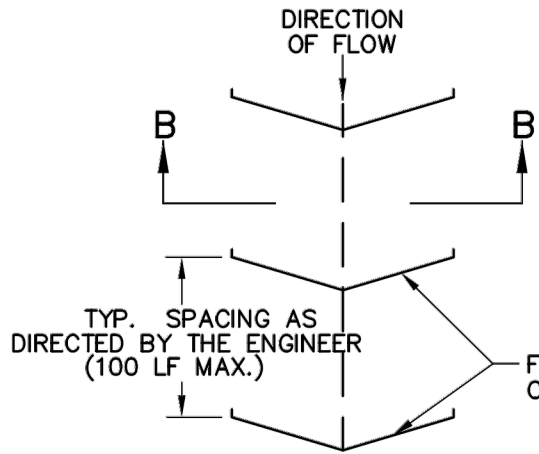

PLAN

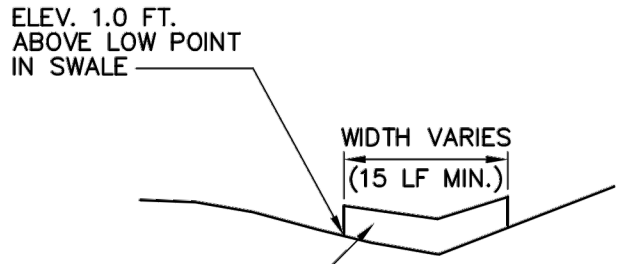

SECTION B-B

**CHECK DAM
FILTER FABRIC OR HAY/STRAW BALES**

(TO BE PAID FOR AS "SEDIMENTATION CONTROL FILTER FABRIC FENCE SYSTEM")

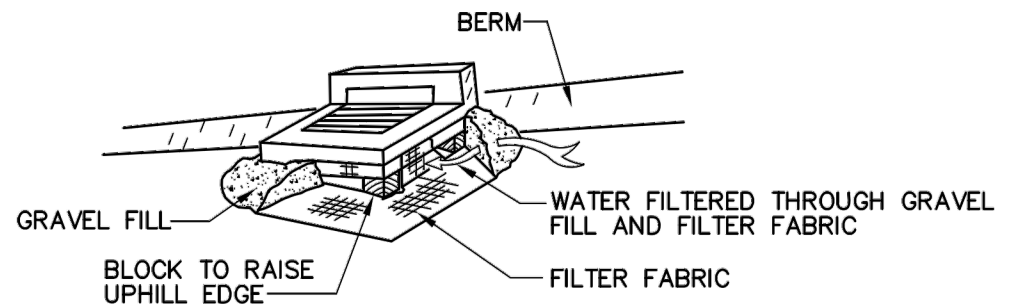

WHERE DIRECTED BY ENGINEER, CONTRACTOR SHALL CONSTRUCT A STONE DIKE IN LIEU OF THE FILTER FABRIC CHECK DAM.

**SEDIMENTATION CONTROL SYSTEM
FOR CATCH BASINS**

NOTE: RAISE AND PROTECT CATCH BASIN TOPS WITH CRUSHED STONE AS SOON AS POSSIBLE TO PERMIT DRAINAGE TO ENTER STORM SYSTEMS, WHEN ROADWAY IS BROUGHT UP TO SUBBASE BEFORE PAVING.

SEDIMENTATION AND EROSION CONTROL DETAILS

NOT TO SCALE

NOTE:
SEE SHEET STD-NH-33A FOR FURTHER DETAILS.

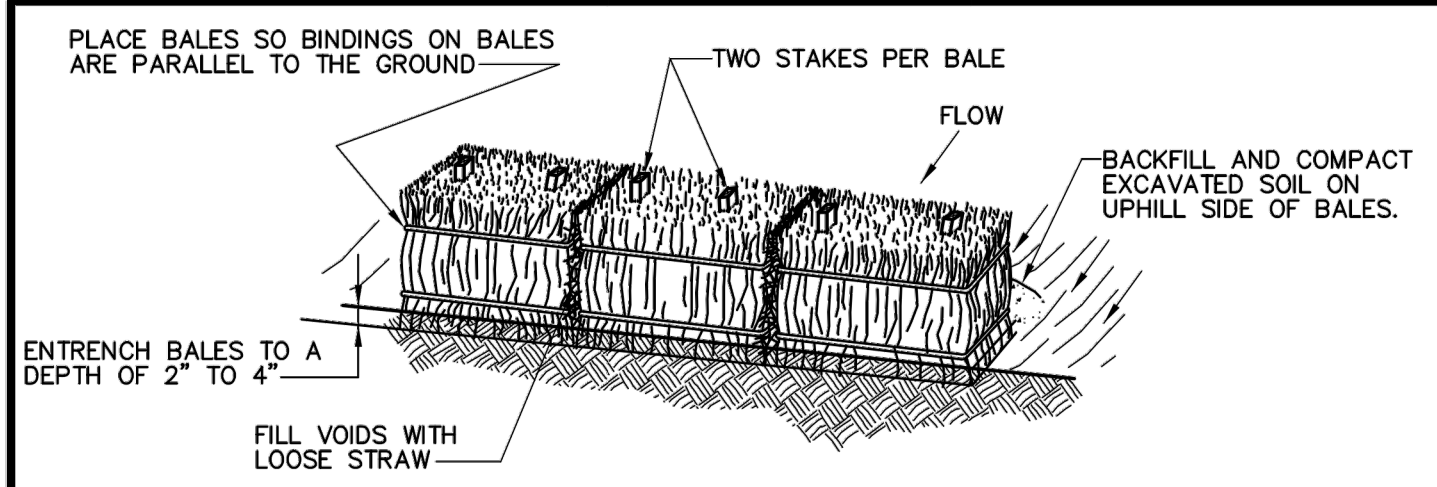

INSTALLATION

- A) IDEALLY, BALES SHOULD BE ENTRENCHED 2 TO 4 INCHES AND TIGHTLY BUTTED TOGETHER. BALES CAN BE SUCCESSFULLY PLACED WITHOUT A TRENCH IF GOOD GROUND CONTACT IS MADE. REMOVE HEAVY BRUSH AND FILL IN ALL VOIDS WITH LOOSE STRAW.
- B) BALES SHALL BE ONLY USED AS A TEMPORARY BARRIER AND FOR NO LONGER THAN 60 DAYS. THEY SHALL NOT BE USED ON A JOB ADJACENT TO A RESIDENTIAL NEIGHBORHOOD, RESIDENCES OR ADJACENT TO OR IN A WATERCOURSE.
- C) WHEN SEDIMENTATION DEPOSITS REACH WITHIN 3" OF THE TOP OF THE BALES, REMOVE SEDIMENTATION OR ADD ADDITIONAL BALES ON SEDIMENTATION DIRECTLY BEHIND THE FIRST ROW OF BALES AS DIRECTED BY THE ENGINEER.
- D) UPON ESTABLISHMENT OF GROUND COVER ON DISTURBED AREAS AND WHEN DIRECTED BY THE THE ENGINEER, HAY BALES WILL BE REMOVED AND USED AS MULCH. ANY SEDIMENTATION WILL BE THINLY SPREAD UPON ESTABLISHED GROUND COVER.

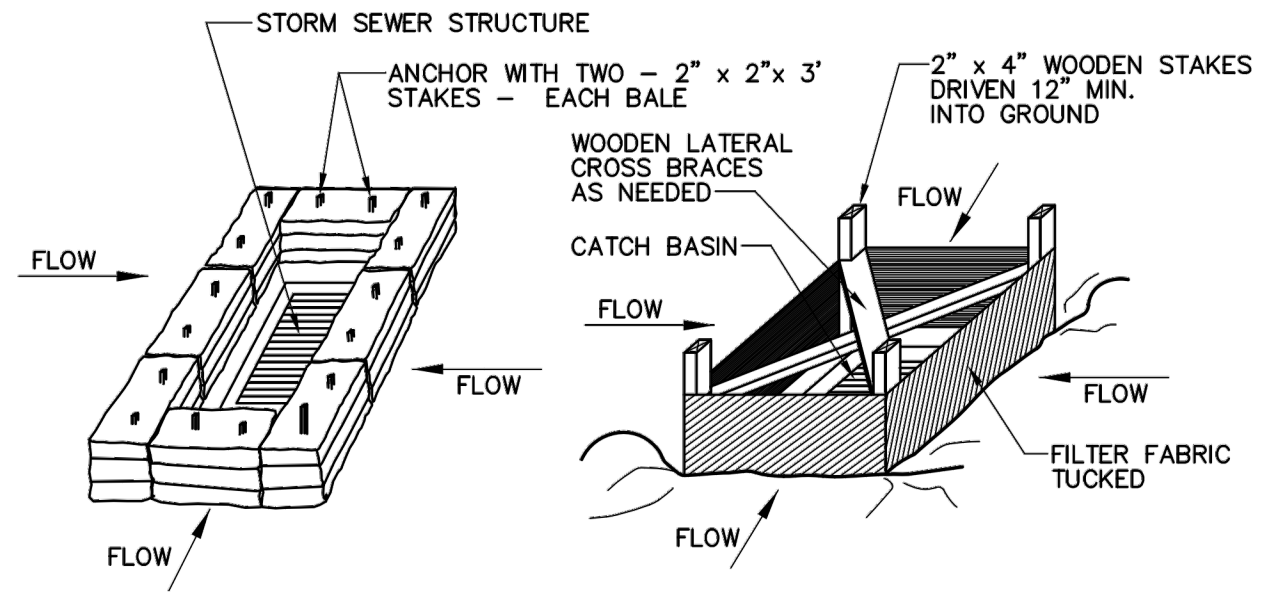

HAY BALE INSTALLATION AT CATCH BASIN

SILT FENCE INSTALLATION AT CATCH BASIN

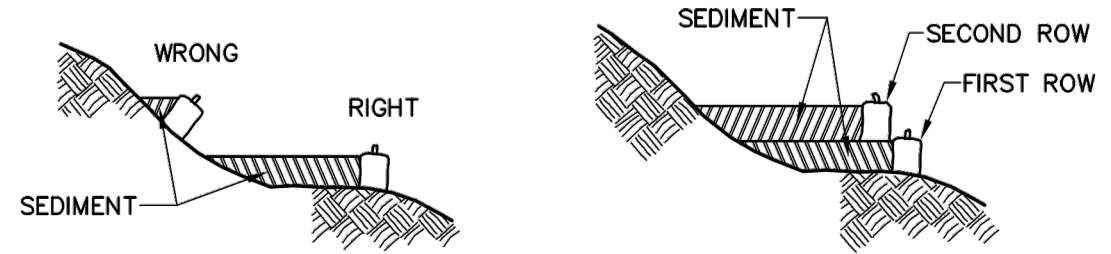

BALE PLACEMENT

PREFERRED PLACEMENT

BALES PLACED AWAY FROM TOE OF SLOPE HAVE A LARGER CONFINEMENT AREA. ADDITIONAL BALES SHOULD BE ADDED BEHIND ORIGINAL BALES BEFORE SEDIMENT TOPS THE FIRST BALE.

CATCH BASIN IN A DEPRESSION

SEDIMENTATION AND EROSION CONTROL DETAILS

NOT TO SCALE

