

city of new haven COMPLETE STREETS DESIGN MANUAL

Adopted September 7, 2010



John DeStefano, Jr., Mayor

NEW HAVEN
IT ALL HAPPENS HERE

City of New Haven Complete Streets Design Manual

2010



John DeStefano, Jr., Mayor



table of CONTENTS

Introduction	7		
1. Policy & Ordinance	11		
1.1 Complete Streets Policy	11		
1.2 BOA Order	11		
2. New Haven Context	15		
2.1 Infrastructure	15		
2.2 Demographics	15		
2.3 Safety Concerns & Community Involvement	16		
3. What are Complete Streets?	19		
3.1 Complete Streets are Public Spaces	19		
3.2 Complete Streets and Land Use	19		
3.3 Complete Streets as Multi-Modal Transportation Network	20		
3.4 Complete Streets are Context Sensitive	20		
4. Why Complete Streets?	23		
4.1 The Status Quo	23		
4.2 Benefits of Complete Streets	23		
4.3 Guiding Principles for New Haven Complete Streets	25		
5. Street Design Process	27		
1. Project Initiation	30		
2. Plan Development	30		
3. Funding & Design	30		
4. Installation	30		
6. Engineering Considerations for Complete Streets	33		
6.1 Guidelines	33		
6.2 Roadway Classification System	35		
6.3 Street Typologies	36		
6.3.1 General Street	36		
6.3.2 Boulevard	37		
6.3.3 Slow Street	37		
6.3.3 Pedestrian Only Street	38		
6.4 Vehicle Target Speed	38		
6.5 Design Vehicles, Emergency Access, Sanitation	39		
6.6 Intersections	39		
6.7 On-Street Parking	40		
6.8 Pedestrian & Bicycle Use	41		
6.9 Public Transportation	42		
6.10 Pedestrian Access In Construction Zones	42		
6.11 Environmental Design	43		
6.12 Land Use Context	44		
7. How to Create Complete Streets	47		
7.1 Complete Streets Toolbox	48		
7.1.1 Sidewalk Widening	48		
7.1.2 ADA Compliant Curb Ramps	48		
7.1.3 Street Furniture	48		
7.1.4 Crosswalks	48		
7.1.5 Tree Belt Enhancements	48		
7.1.6 Sidewalk Surface Treatments	49		
7.1.7 Roadway Surface Treatments	49		
7.1.8 Pavement Markings	49		
7.1.9 Speed Humps	49		
7.1.10 Refuge Islands	49		
7.1.11 Bump-outs/Chokers	50		
7.1.12 Chicanes	50		
7.1.13 Diverters	50		
7.1.14 Road Closures	51		
7.1.15 Traffic Patterns	51		
7.1.16 Bike Routes	52		
7.1.16 Bike Routes, continued	53		
7.1.18 Bike Boulevards	53		
7.1.19 Bike Parking	53		
7.1.20 Shared Lane Markings	53		
7.1.21 Bike Signage	54		
7.1.22 Roadway Narrowing	54		
7.1.23 Mini Roundabouts	55		
7.1.24 Roundabouts	55		
7.2 Other Complete Streets Tools	56		
7.3 What NOT To Do	56		
8. Measurement: Making it Count	59		
8.1 Why Measure?	59		
8.2 Who to Measure?	60		
8.3 What to Measure?	60		
8.3.1 Objective Data	60		
8.3.2 Subjective Data	61		
8.4 When & Where to Measure	61		
9. Funding, Future Strategy & Review Process	65		
9.1 Funding	65		
9.1.1 City of New Haven	65		
9.1.2 State of Connecticut / South Central Regional Council of Governments	66		
9.2 Future Strategy	67		
9.2.1 Overview	67		
9.2.2 Key Early Milestones	69		
9.3 Enforcement of Traffic Violations	69		
9.4 Streets Smarts Educational Campaign	70		
9.5 Periodic REview Process	70		
Notes	71		
Appendices	73		
Appendix A: Project Request Form	75		
Appendix B: Roadway Classification Map	77		
Appendix C: Land Use Map	79		
Appendix D: Standard Details	81		
Appendix E: Decision Matrix	103		
Appendix F: Bicycle Boulevards	105		
Appendix G: Bicycle Parking	107		
Appendix H: Tree Policies	113		

Introduction

On October 23, 2008, The New Haven Board of Aldermen unanimously passed an order creating a nine member Complete Streets Steering Committee to guide the development of the following elements for the purpose of addressing the status of city streets: policy document, design manual, public process, educational campaign and traffic enforcement.



BOA REPRESENTATIVES

- » Michele Edmonds-Sepulveda, Ward 30
- » Roland Lemar, Ward 9
- » Erin Sturgis-Pascale, Ward 14

CITY REPRESENTATIVES

- » Karyn Gilvarg, City Plan
- » Richard Miller, Engineering
- » Michael Piscitelli, Transportation Traffic & Parking

CITIZEN REPRESENTATIVES

- » Tokunbo Anifalaje
- » Thomas Harned
- » Sylvie Rivetta

OTHER PARTICIPANTS

- » Susmitha Attota, New Haven City Plan
- » Rachel Bright, Fitzgerald & Halliday, Inc.
- » Emily Byrne, New Haven Mayor's Office
- » Michael Morehouse, Fitzgerald & Halliday, Inc.
- » Howard Weissberg, New Haven Public Works

BOOK DESIGN

- » Caroline Ehorn
- » Rachel Bright

This document fulfills the above mandate to create a design manual for the development of progressive design guidelines. It provides technical guidance on the building, rebuilding, repair and rehabilitation of city streets with the intent of balancing the needs of all users. It is guided by a set of principles appropriate for an evolving understanding of the importance of streets to the social and economic fabric of a community. Additionally, this manual is intended to provide the citizens of New Haven the tools and information needed to engage in constructive conversations about solving local traffic problems with City staff.

To guide our work, the Complete Streets Steering Committee developed the following mission statement: **To develop and promote a safe, context-sensitive transportation network that serves all users and integrates the planning and design of complete streets that foster a livable, sustainable and economically vibrant community.**

By articulating the many roles of city streets and linking their impact to larger policy goals, we are providing a focus for the considerable public investment in these streets. Rather than a static delivery of a narrow service that is divorced from the aspirations of our city, we acknowledge that street building will play a central role in the long-term health and vitality of our community. This manual strives to provide the framework for this transformation by enlisting our public infrastructure investments in the effort to address a host of critical issues that face our city.

It is our hope that this document, along with the companion components of the Complete Streets order, will provide immediate guidance to on-going projects as well as forming the base upon which future strategies will be developed.

Respectfully Submitted,
Complete Streets Steering Committee Members

complete streets
POLICY & ORDINANCE

chapter 1

1. Policy & Ordinance

1.1 COMPLETE STREETS POLICY

The City of New Haven shall require the accommodation of the safety and convenience of all users of the transportation system using a hierarchy of users which supports and encourages non-motorized transportation and prioritizes the needs of the most vulnerable users: children, the elderly and persons with disabilities. This accommodation will be executed through the application of the complete street designs guidelines described in the Complete Streets Design Manual.

1.2 BOA ORDER

The order of the New Haven Board of Aldermen specifies the creation of a policy that:

- a. requires the accommodation of the safety and convenience of all users of the transportation system using a Complete Streets hierarchy of users, which begins with pedestrians, bicyclists, transit users. These users shall be accommodated and balanced in all types of transportation and development projects and through all phases of a project so that the vulnerable – children, elderly, and persons with disabilities – can travel safely within the public right of way;
- b. mandates the application of this policy, through adherence to principles of the Design Manual, to any new or improvement project affecting the public streets and sidewalks (including resurfacing, restoring, and rehabilitation projects);
- c. prioritizes walkability, inter-modal transit, traffic calming and pedestrian-based urban economic development over competing goals; and
- d. references performance standards, with measurable outcomes and benchmarks.

Various improvements are subject to review by City Plan, the [Legal Traffic Authority](#), the Board of Aldermen, other state and federal agencies, and partners in the Complete Streets process.

who?
NEW HAVEN CONTEXT

chapter 2

2. New Haven Context

The City of New Haven is committed to creating a safe and sustainable transportation system for all of its residents, visitors and businesses. The Complete Streets Manual reflects this commitment and our priority emphasis on education, enforcement and physical change to city streets.

New Haven streets are public spaces. Thousands of people walk through the downtown area, the medical district and our neighborhoods every day. Likewise, bicycles have replaced the car for many residents and cyclists are on city streets at every hour of the day. Shifting demographic patterns, combined with the rising cost of fuel and the tremendous growth in downtown all suggest that even more people will be walking and cycling on city streets in the coming years.

2.1 INFRASTRUCTURE

The City of New Haven encompasses an area of a little more than 18 square miles. We have 232 miles of streets occupying 11% of our land area. We have 340 miles of sidewalk and approximately 68 million square feet of buildings. Because it is an older city with a street system mostly laid out prior to the advent of the automobile, New Haven is in many ways ideal for walking and cycling. The terrain is not too hilly, and most of the city's streets are laid out in a grid pattern with reasonably short blocks and relatively narrow roadways compared with surrounding communities. Though our street design and management has for many years prioritized motorized transportation, we have a strong foundation on which to create Complete Streets.

2.2 DEMOGRAPHICS

The current population of New Haven is 126,000 (2007 ACS estimate). Of the 10 largest cities in New England, New Haven has the highest percentage of residents who walk to work (13.6%) and the highest proportion of persons using non-motorized means to journey to work, (15.5%). This is undoubtedly due in many cases to choice; in other cases to necessity, as New Haven has poverty rates approaching 25%. Daily ridership on commuter rail is equally impressive, with 1,100 people now arriving at New Haven on Shoreline East, 2,000 arriving via MetroNorth Railroad, and 23,000 using CT Transit bus lines.

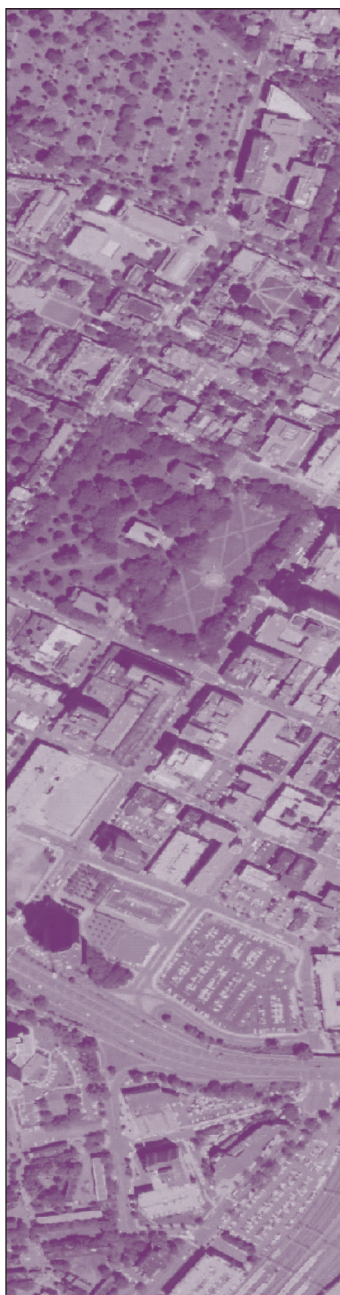

2.3 SAFETY CONCERNS & COMMUNITY INVOLVEMENT

The Complete Streets ordinance and Design Manual are part of the City of New Haven's response to community alarm over the number and severity of traffic accidents. In 2008, two pedestrian fatalities galvanized the community and led to the formation of the New Haven Safe Streets Coalition. The coalition is comprised of residents, civic leaders, city officials and organizations to improve traffic safety in the City. Their advocacy has led to programs sponsored by Elm City Cycling, Yale University, the Yale Medical School's Traffic Safety Committee, and the Connecticut Department of Transportation. The City of New Haven has partnered with the coalition, and city staff is engaged on various levels from policy to technical support.



what?
WHAT ARE COMPLETE STREETS

chapter 3

3. What are Complete Streets?

Complete Streets are designed and operated to enable safe access for all users, including pedestrians, bicyclists, motorists and transit riders of all ages and abilities. Complete Streets may look different and contain different elements depending on the location. In urban communities like New Haven, the concept of Complete Streets goes beyond safety, tying in with issues of human health, equity, aesthetics, economic development, environmental protection, and livability, all within a specific neighborhood context.

Complete Streets represents a paradigm shift in traditional road construction philosophy. Instead of a reactive attempt to accommodate bicycle- and pedestrian-friendly practices in projects, Complete Streets policies require all road construction and improvement projects to begin by evaluating how the right-of-way serves all who use it.¹



New Haven Road Race



Chapel Street, New Haven

3.1 COMPLETE STREETS ARE PUBLIC SPACES

Above any specific need by an individual or group of users, the city street is a public space. Due to New Haven's density and pre-automobile neighborhood layouts, our streets are literally our front yards. At their best, streets:

- Create space for social interaction and physical activity
- Provide a clean and attractive framework for economic development
- Embrace the vernacular of a place thereby defining a unique identity
- Provide for the safe and efficient movement of goods and people of all ages and abilities

3.2 COMPLETE STREETS AND LAND USE

In urban communities like New Haven, the comparatively short distances between people and services due to compact development make walking, cycling and transit use reasonable travel choices. The density of habitation provides important commercial opportunities. For us, street design that is inherently safe for all users, that encourages the use of non-motorized transportation, and that creates a varied and lively streetscape is essential to our social and economic success.



Transit in downtown New Haven

3.3 COMPLETE STREETS AS MULTI-MODAL TRANSPORTATION NETWORK

Complete Streets provide a choice of mobility options that are viable over the lifetime of a user, including facilities that make walking, cycling and transit use comfortable, attractive, and efficient transportation options. They provide connectivity between destinations and travel modes, as well as redundant travel routes to make pedestrian circulation easier. Complete Streets are streets where all users coexist in a controlled, low-speed environment. These users may include:

- Pedestrians of all ages and abilities, including children, who are small, hard to see, and may be impulsive, as well as seniors and disabled individuals, who may be unable to move quickly
- Cyclists – utility and recreational users of all ages
- Transit users and vehicles, including public and school buses
- Emergency access for Police, Fire and Ambulance services
- Commercial trucks and vehicles for delivery of goods and services
- Private motor vehicles and their drivers

3.4 COMPLETE STREETS ARE CONTEXT SENSITIVE

Complete Streets are designed to respect the context of their location. Urban locations, for example, often require greater emphasis on pedestrian, bicycle, and transit access than more rural locations. Context includes elements such as:

- Adjacent land uses – residential, commercial, institutional, etc.
- Neighborhood density – influences how many people are likely to use the street.
- Neighborhood character and aesthetics – historic architecture, development patterns, waterfront site, etc.
- Existing transportation system – roadway classification, transit availability, street parking, limited rights-of-way.

Additionally, context includes social and demographic factors that influence who is likely to use the street and how. For example, low income families and those without their own car are likely to need a robust pedestrian network that connects to important destinations and allows them to travel by foot safely and efficiently. They also need plentiful access to transit and bicycle facilities. According to census data, 30% of households in New Haven lacked access to a vehicle in 2000², and more recent estimates reveal similar figures. Likewise, elderly residents may be highly dependent on pedestrian travel and also need special consideration in crosswalks, such as longer crossing times.

Key Demographics

- » Elderly residents
- » Disabled residents
- » Child residents and/or nearby schools
- » Low to moderate income households
- » Households without access to a car

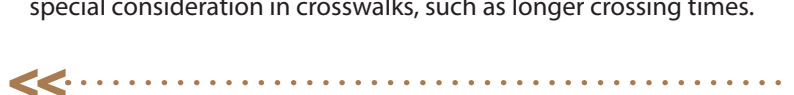

why?
REASONS FOR COMPLETING THE STREETS

chapter 4

4. Why Complete Streets?

Societal costs of existing transportation system:

- air pollution
- crashes & injuries
- climate change
- cost of car ownership
- decline in civic behavior (road rage)
- energy insecurity
- increasingly sedentary lifestyle & deteriorating human health
- local capital
- lower productivity from congestion
- maintenance costs
- noise
- operations costs
- parking
- sprawl & inefficient urban land use
- water pollution

4.1 THE STATUS QUO

The City of New Haven is committed to a safe and sustainable transportation system for all of its residents, visitors and businesses. The City is also committed to supporting and encouraging the use of non-motorized transportation. These goals, however, exist in the context of a street system that, despite being mostly laid out prior to the advent of the automobile, has since been engineered to facilitate and prioritize the movement of people and goods in and out of the city via motor vehicles, resulting in the subordination of non-motorized transportation and related land uses such as shopping, recreation, residential uses and other social activities.

It has become clear that maintaining and furthering this current transportation model is costly to our community in many ways. The sidebar lists some specific societal costs associated with the current transportation system.



4.2 BENEFITS OF COMPLETE STREETS

By rethinking commonly applied planning and design practices, and orienting our street design and management toward Complete Streets, we intend to alter the balance of power in ways that impress upon users that the street has many purposes and is not simply a travel corridor dedicated exclusively to motor vehicle traffic. At the same time, we can improve the driving environment for motorists by encouraging more cooperative sharing from pedestrians and cyclists, improving the quality of travel through the reduction of unwarranted stops, and smoothing flow in a way that lowers stress and anxiety while encouraging slower and safer travel speeds.

The National Complete Streets Coalition has identified the following specific benefits of Complete Streets² :

- Complete Streets improve safety. A Federal Highways Administration safety review found that streets designed with sidewalks, raised medians, better bus stop placement, traffic-calming measures, and treatments for disabled travelers improve pedestrian safety, and many other design elements improve safety for all users.
- Complete Streets encourage walking and bicycling for health. The National Institutes

Vision Zero

The ultimate measure of Complete Streets in New Haven is the number of traffic-related injuries and fatalities. The City of New Haven rejects the assumption that traffic crashes are inevitable in a mobile society and will work to develop a street network that can tolerate mistakes without risking human life.

In the words of Claes Tingvall, Sweden's Director of Traffic Safety and the architect of Sweden's Vision Zero Policy: "The Vision Zero policy is not a figure; it is a shift in philosophy. Normal traffic policy is a balancing act between mobility benefits and safety problems. The Vision Zero policy refuses to use human life and health as part of that balancing act; they are non negotiable."

New Haven embraces the Vision Zero policy and will work towards achieving and maintaining the goal of zero traffic related injuries and fatalities in our city.

of Medicine recommends fighting childhood obesity by establishing ordinances to encourage construction of sidewalks, bikeways, and other places for physical activity. One study found that 43% of people with safe places to walk within 10 minutes of home met recommended activity levels; among individuals without safe place to walk, just 27% were active enough.



Walk to School Day, New Haven

- Complete Streets address climate change and oil dependence. The 2001 National Household Transportation Survey found 50% of all trips in metropolitan areas are three miles or less and 28% of all metropolitan trips are one mile or less – distances easy to walk, bike, or hop a bus or train. Yet 65% of the shortest trips are now made by automobile, in part because of incomplete streets that make it dangerous or unpleasant for other modes of travel.
- Complete Streets foster strong communities. Complete Streets play an important role in livable communities, where all people – regardless of age, ability or mode of transportation – feel safe and welcome on the roadways.

4.3 GUIDING PRINCIPLES FOR NEW HAVEN COMPLETE STREETS

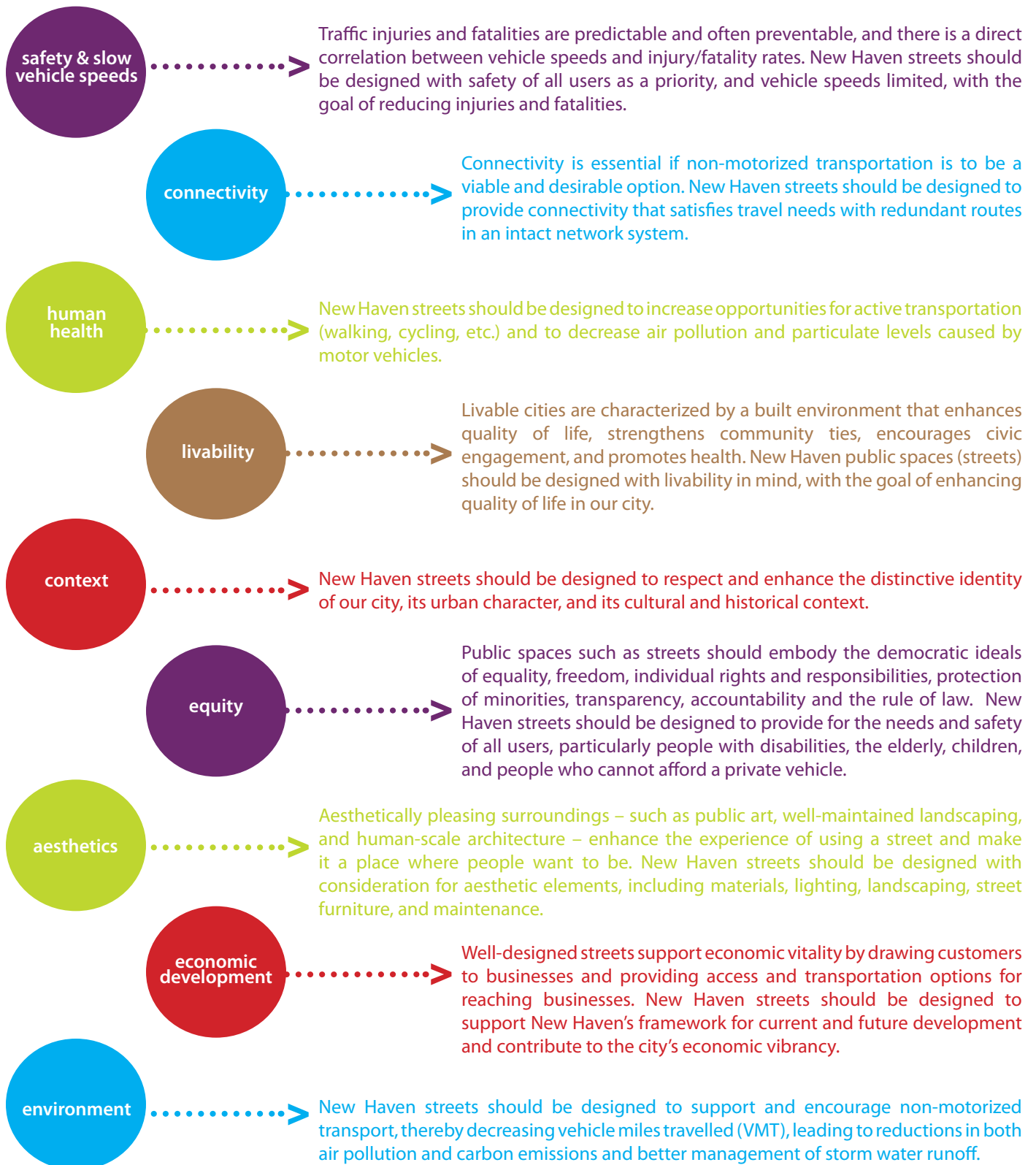

what now?
STREET DESIGN PROCESS

chapter 5

5. Street Design Process

The Complete Streets Design Manual aims to formalize a process for community participation in the street re-design processes in the City of New Haven. While the City has a history of working with community groups to address traffic safety problems, public interest in the details of such processes have reached historic levels. For this reason, it is timely to develop a protocol for constructive engagement between community members and city staff.

Such a process provides the best opportunity for transparency and accountability from both parties. City staff will not need to risk angering residents and residents need not submit to changes without a process through which their concerns can be addressed. Projects can be initiated either by community request or through the on-going maintenance and reconstruction done by the City. Both 'work flows' are subject to an open design process guided by the goals outlined in this document. This will ensure that infrastructure investments will support not only mobility, but the guiding principles of Complete Streets—connectivity, human health, safety, equity, aesthetics, economic development, environmental protection and livability—as prioritized jointly by neighbors and city staff.

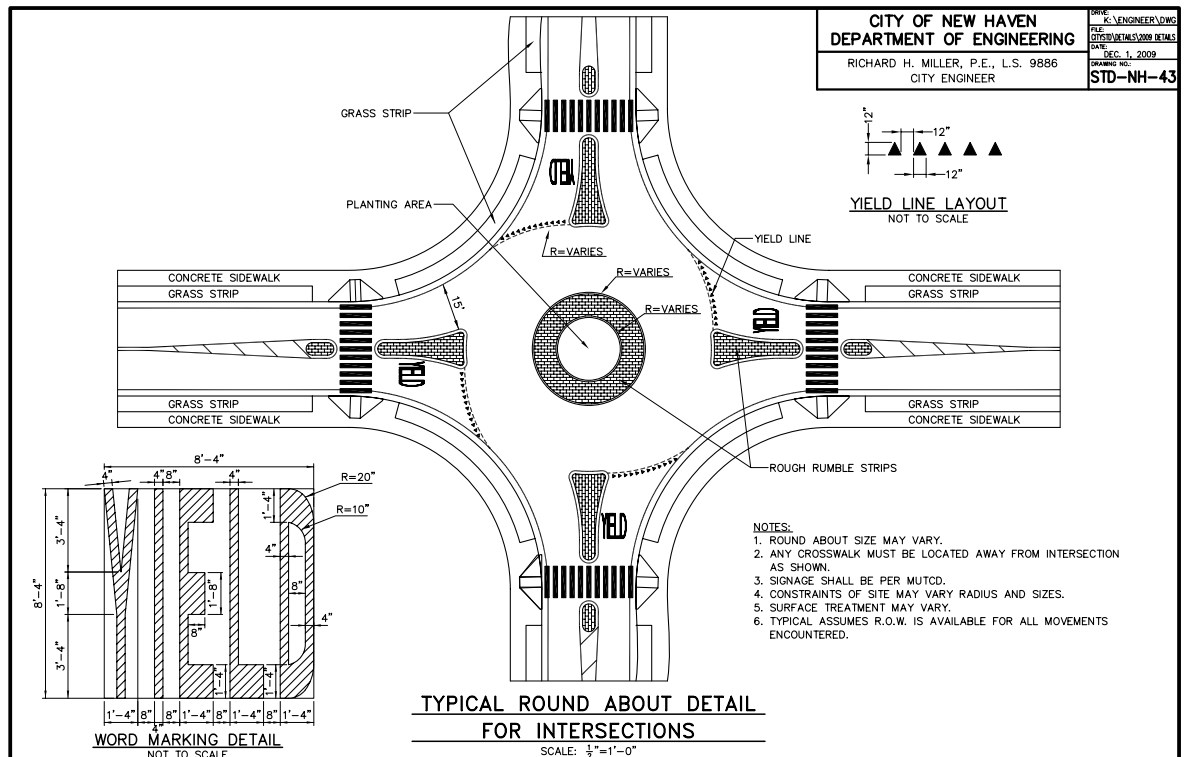

The citizens of the City of New Haven have a vested interest in the changes that occur in the public spaces of their communities, including their streets. Given access to pertinent information, input from qualified professionals and a participatory process that allows for thoughtful collaboration between educated citizens and city staff, final street designs will result in changes that most clearly reflect the desires and needs of the community.

The steps described below can assist New Haven residents, neighborhood groups, elected officials and City staff in navigating a street design process that will effectively address traffic, safety and other street-related issues.

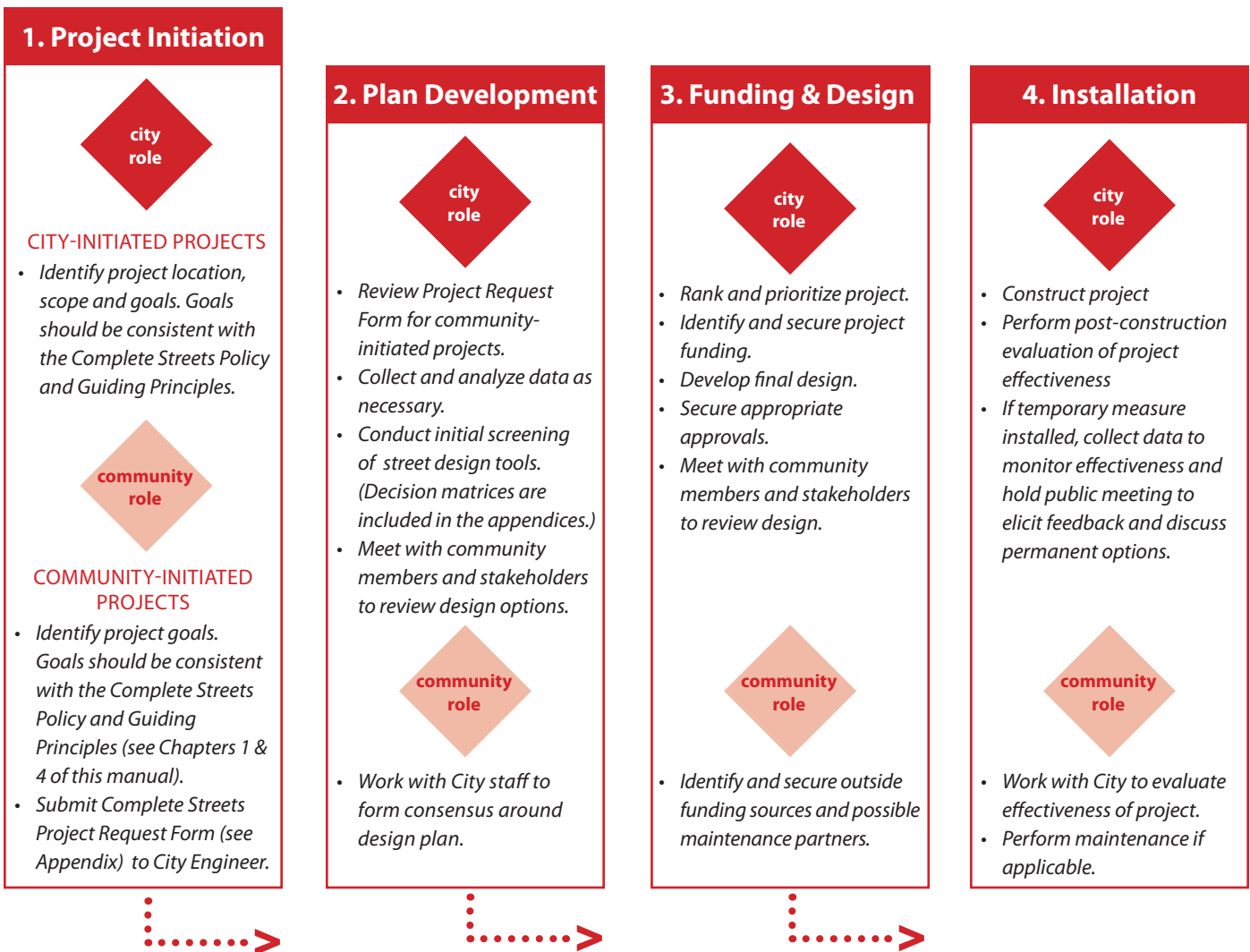

what else?
ENGINEERING CONSIDERATIONS

chapter 6

6. Engineering Considerations for Complete Streets



The Complete Streets program is part of a fundamental shift in the way the City of New Haven approaches street design. For Complete Streets to be successful, every road project for every type of roadway should be evaluated for compliance with the Complete Streets policy and guiding principles. Road projects range from minor crack sealing and preventative maintenance to milling and paving to new or realigned roads. Road types range from industrial arterials carrying high volumes of traffic to low volume roads carrying residential traffic only.

The modification of the road or transportation system must be thoughtfully considered based on proven and accepted criteria; furthermore, techniques applied in one location may not be suitable in another. All designs must be professionally driven and approved by the City Engineer to ensure that they meet the criteria of safety, feasibility, and proper application. Below are some of the factors that must be taken into consideration in the course of all roadway designs.

6.1 GUIDELINES

In order to provide consistency and reduce the potential for conflicts, roadway projects must be designed with consideration for nationally and regionally recognized guidelines and standards. The City of New Haven has adopted criteria for signage, lanes widths, pavement marking dimensions, turning radii and other road characteristics for many roadway design treatments. Standard details for some of these treatments are included in the Appendix, and others are available from the Engineering Office. "Pilot" geometry or any other proposed designs that deviate from accepted standards will be evaluated on a case by case basis, and will in all cases be subject to the judgment of the City Engineer.

Below is a list of sources that provide commonly accepted guidance for street design. These resources provide references to engineers but generally allow for considerable flexibility.

- » American Association of State Highway and Transportation Officials (AASHTO), which publishes the following:
 - » “Geometric Design of Highways and Street,” a primary reference for any transportation design. It covers most geometric considerations for the design of roads and highways and should be considered as a good reference to provide a basis for design, though it allows for flexibility and engineering judgment.
 - » “Guide for the Planning, Design, and Operation of Pedestrian Facilities”
 - » “Guide for the Development of Bicycle Facilities”
 - » “Guide for Achieving Flexibility in Highway Design”
- » The Federal Highway Administration (FHWA), which publishes the following applicable documents:
 - » Manual on Uniform Traffic Control Devices (MUTCD)
 - » FHWA Traffic Calming State of the Practice.
 - » National Committee on Uniform Traffic Control Devices
- » Americans with Disabilities Act (ADA) guidelines
- » City of New Haven Engineering Standards
- » The South Central Connecticut Regional Council of Governments (SCRCOG) Traffic Calming Resource Guide

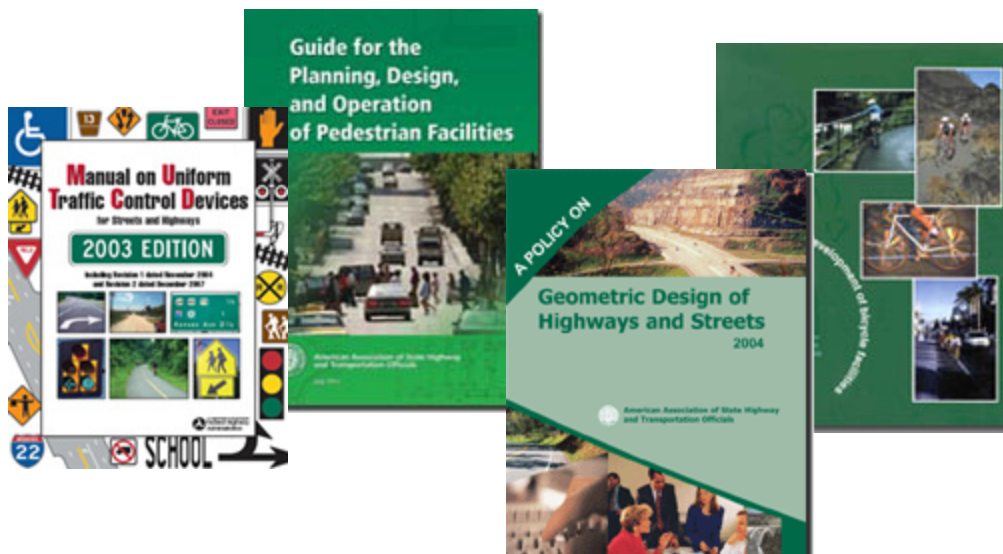

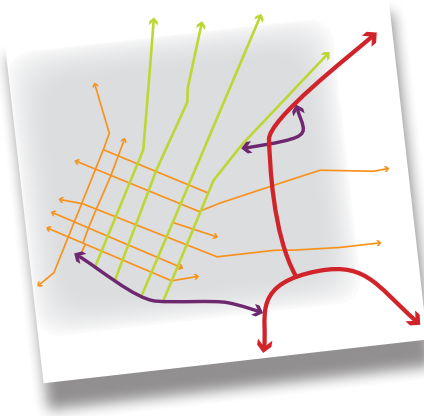

6.2 ROADWAY CLASSIFICATION SYSTEM

Like most jurisdictions in the United States, New Haven's streets have been categorized in order to better understand how they serve motor vehicle traffic. Each road's classification has been determined by the state using guidelines developed by AASHTO. Complete Streets projects must take into consideration this roadway classification as it helps determine how the road and network needs to be treated to handle the traffic volumes and other conflicts that may arise as a result of design changes. It is also often used in determining Federal or State funding criteria when improvements are needed. The road classifications for the urban environment of New Haven are as follows:



Urban Principal Arterial – Serves major centers of activity and have the highest traffic volumes and longest trips. Generally carries urban commuters. Examples include I-95 and I-91, as well as Whitney Avenue, Whalley Avenue and Ella T. Grasso Boulevard.



Urban Minor Arterial – Serves to interconnect with principal arterials and other roads and has a lower level of travel mobility. Often used for transit. Examples include Sherman Avenue, Goffe Street, Chapel Street and State Street.



Urban Collector – Provides land access and traffic circulation in residential neighborhoods, commercial and industrial areas. Examples include Winchester Avenue, Humphrey Street and Olive Street.



Urban Local Road – Provides primary access to residential land and abutters. Through traffic is discouraged.

See Appendix for New Haven Roadway Classification Map.





Downtown New Haven

6.3 STREET TYPOLOGIES

Some jurisdictions go beyond roadway classification to categorize streets into broader “typologies” that account for non-motorized road users (pedestrians, bicyclists, and transit) as well as land use context and environmental factors. Such typologies complement the Complete Streets paradigm as they allow for a more comprehensive understanding of a street’s existing and desired functions. While the City of New Haven does not currently categorize streets this way, the four typologies described below should be considered as part of a comprehensive evaluation of what design treatments might be appropriate for a given street. (Both roadway classification and typologies are factored into the Decision Matrix presented in Chapter 7.)

Street typologies below are taken from Section 1.3 of the New York City Street Design Manual⁴.

6.3.1 General Street

With a mixed-use roadway, curbs, and sidewalks, **General Streets** are the most prevalent street design and can be tailored to serve both local and through street contexts.

Although this design frequently emphasizes motor vehicle access and movement, the street may also include dedicated facilities for other users. Unlike a shared street, vehicles and pedestrians are typically separated rather than cooperatively sharing the street space.



Clark Street, New Haven

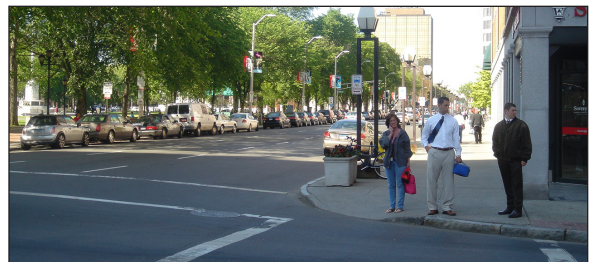

Church Street, New Haven

6.3.2 Boulevard

Boulevards are wide streets with multiple roadways and medians and an emphasis on greening and design quality. They typically have two or more roadways separated by medians, with the inner roadway(s) intended for through traffic and the outer for local traffic, and an exceptional level of landscaping, public open space, and visual quality. The medians sometimes include pedestrian and bicycle paths. Note that not all streets designed as boulevards are named “Boulevard” and vice versa.



Bellevue, Washington

6.3.3 Slow Street

Slow Streets are local streets that makes extensive use of traffic calming measures to discourage vehicular through traffic, reduce vehicle speeds, green and beautify the streetscape, and create a comfortable environment for bicycling and walking. Variations of the Slow Street include “Home Zones” or “Woonerfs” where pedestrian and bicycle access is prioritized and all users share the road space without boundaries such as lanes and curbs. Such streets were popularized in Europe and are gaining gradual acceptance in the United States. Slow Streets are especially well-suited to local residential streets and streets adjacent to schools. Slow streets should be paired with a reduced speed limit.



Audubon Street, New Haven

6.3.3 Pedestrian OnlyStreet

Pedestrian streets usually involve the full-time restriction of vehicle access to a street, however delivery access may be allowed in off-hours. Bicyclists can either be allowed to ride through or be required to dismount and walk. Streets can also be designated “pedestrian-only” during specific time periods rather than full-time.



Court Street, New Haven

6.4 VEHICLE TARGET SPEED

Vehicle target speed is the 85th percentile speed that is desired for a given street. Lowering vehicle speeds directly impacts the severity and number of crash related injuries and fatalities and is a primary goal for Complete Streets.

Target speed can be achieved through a combination of engineering treatments, driver education, and police enforcement. Streets should be designed with target speeds and speed limits that are appropriate for both their current and future context, including roadway classification and street type, as well as adjacent land uses and user demand.

Specific design treatments are capable of achieving predictable speed and volume reductions, though their benefits must be balanced with the potential impacts on parking and emergency vehicles. On local roads and in school zones, target speeds should be set at or below 20 MPH in order for pedestrian safety to be maximized.



6.5 DESIGN VEHICLES, EMERGENCY ACCESS, SANITATION

A design vehicle is the vehicle-type that must regularly be accommodated on a roadway for the purpose of designing the road. The design vehicles used for geometric street designs should reflect the predominant intended users of the street in question. In addition, all street designs must meet minimum standards for fire department and other emergency vehicle access and must consider the needs of sanitation vehicles used for street cleaning, refuse collection, and snow clearing.

6.6 INTERSECTIONS

Intersections are statistically the most dangerous part of the street network as they are complex environments where a variety of users are negotiating the same space. Since the chance for conflict between users is highest at intersections, special care must be taken to implement design elements that control vehicle speed and minimize conflict points.

The use of the smallest possible turning radii, raised intersections, crosswalks, lighting, textured pavement, roundabouts and other speed mitigating design elements should be prioritized whenever possible to improve the safety for all users.

Church and Chapel Street Intersection

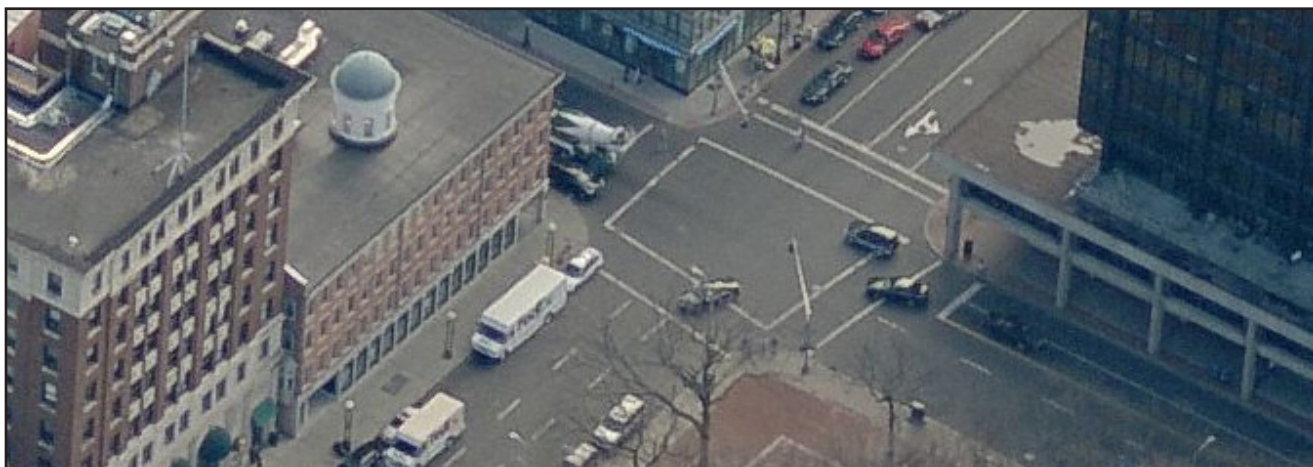

Source: Microsoft Bing

6.7 ON-STREET PARKING

In New Haven, on-street parking offers a number of important benefits. The availability of the appropriate amount of on-street parking is an important factor for many residential streets where historical homes did not allocate space for vehicles. On-street parking is also necessary for supporting businesses in Downtown New Haven and neighborhood 'main street' business districts. On-street parking is more efficient than off-street parking as on-street spaces are more likely to be shared by a number of users.

When properly oriented, on-street parking can also have a traffic calming effect by slowing vehicle speeds. For instance, when combined with chicanes, on-street parking can break up straight stretches of roadway. Throughout the city, there are opportunities to substantially increase the number of parking spaces available while simultaneously narrowing the roadway through the replacement of parallel parking with reverse angle parking or simply by striping the parking spaces in the roadway.

The benefits of on-street parking should be only be implemented with the use of appropriate design elements to avoid negative consequences. Cars parked on the street can block access to crosswalks and impede sightlines for other users. The space that is dedicated to parking cannot be used for bike lanes and the very presence of parking encourages driving; therefore, parking needs to be carefully managed and incorporated into a larger complete streets plan. One important management tool is ensuring, wherever appropriate, that on-street parking be properly priced through meters, kiosks, or residential parking permits.

6.8 PEDESTRIAN & BICYCLE USE



Pedestrians in downtown New Haven



Cyclist in downtown New Haven



Pedestrians in Sherman's Alley,
New Haven

The Complete Streets policy requires that all roadway designs take into consideration use by pedestrians and bicyclists of all ages and abilities. Factors that contribute to a good environment for walking include the following:

- Pleasant visual environment
- Continuous and connected pedestrian facilities separated from vehicle traffic movements
- Short street crossing distances
- A good mix of land uses
- Pedestrian scale lighting
- Slow and controlled motor vehicle movements

Factors that contribute to a good environment for cycling include the following:

- a well-connected network of bicycling facilities
- safe travel routes
- direct travel routes, particularly when bicycling for purposes other than strictly exercise or recreation
- Slow and controlled motor vehicle movements

The following data should be considered in order to evaluate and prioritize needs and choose appropriate design treatments:

- Speed – High vehicle speeds are incompatible with safe pedestrian and bicycle environments.
- Existing pedestrian and/or bicycle volumes – Volume counts, or observations over time are useful.
- Major pedestrian/bicycle generators – Schools, hospitals, shopping areas, parks, transit points, libraries and centers of neighborhood interest often generate pedestrian traffic. Also consider new or planned developments which may generate pedestrian/bicycle traffic not reflected in existing volume counts.
- Accident Data – Higher than average numbers of pedestrian or bicycle accidents with vehicles often indicate the need for traffic calming measures and/or pedestrian/bicycle improvements.
- Street Classification – The purpose of the road and the volume of vehicle traffic combined with heavy pedestrian or bicycle movements requires careful planning, particularly on arterials.
- Other considerations include school walking zones, transit routes, commercial areas, neighborhood characteristics, and development.



6.9 PUBLIC TRANSPORTATION

Public transportation and Complete Streets are naturally complimentary. Transit vehicles operating on New Haven's street serve people who live, work, shop and recreate in the city. Not only must transit vehicles interface with general traffic, but passengers are also pedestrians for a portion of their trip. Also, Complete Streets are those which facilitate intermodal transfers and prioritize the needs of many different users.

Road projects in the city should consider the presence of transit vehicles, stops, and locations where passengers must cross the roadway or use sidewalks to access the system. Traditional road construction projects can exclude the needs of transit users in the design phase, so the Complete Streets process will provide opportunity to prioritize transit improvements in such projects.

Incorporating transit more effectively in road projects may increase the usage of the transit system over time. Safety, convenience and comfort are important considerations for transit users. Well designed streets can improve the pedestrian or bicycle interface with the transit system and encourage more people to use alternative modes of transportation. Complete Streets that prioritize transit can also improve the running time of buses which can make transit more competitive with cars.

6.10 PEDESTRIAN ACCESS IN CONSTRUCTION ZONES

Complete Streets require that protected pedestrian facilities are maintained during all phases of construction projects that encroach upon the public right of way. The Transportation, Traffic and Parking Department reviews right-of-way and encroachment permit applications. As part of that effort, the department's policy is to maintain safe pedestrian access at construction zones. If pedestrian traffic is directed across a street, temporary controls, including ADA accessible mid-block ramp systems, are often required to reduce pedestrian travel delay.



6.11 ENVIRONMENTAL DESIGN

Roadway designs should enhance both the environmental quality and aesthetic appeal of streets. Elements such as landscaping and street trees accomplish both of these goals, reducing air pollution and improving stormwater control, while contributing to a pleasant and appealing environment for street users.

A tree belt is recommended between the curb and the project property line whenever possible. The width of the tree belt should be as wide as possible. A minimum width of 5' is desired unless site conditions do not make this width feasible. Lawn is the preferred surface within the tree belt to maximize the soil volume and to promote tree growth and vitality. If lawn is not feasible as a surface within the tree belt, then adequate openings within paved areas should be provided for placement of soil to support tree growth. More information on New Haven's street tree policy can be found in the Appendix.

Drainage plans should incorporate elements such as bioswales, which are landscaped depressions between sidewalks and streets. Bioswales detain water and allow it to be absorbed into the ground, reducing runoff into the sewer system, while at the same time providing space for aesthetic enhancement landscaping. Stormwater runoff can also be reduced through the use of permeable paving materials. The use of these materials should be prioritized whenever possible.

Appropriate city agencies and abutting neighbors should be engaged in the design process to ensure that street elements can be properly maintained.

6.12 LAND USE CONTEXT

Street designs should take into consideration the context of adjacent land uses. Designs appropriate for low-density residential neighborhoods, such as East Shore, are not likely to be well-suited for the downtown core, which has a much higher number of pedestrians and transit users. Likewise, industrial areas with large volumes of truck traffic generally need wider travel lanes and larger curb radii, elements which should be avoided in commercial and residential areas. In such locations, however, speed reducers and other engineering treatments can be employed while accommodating the needs of large vehicles. For example, the speed humps on River Street (below) slow traffic without impeding truck access. In all cases, streets should be designed with safety of all users as a priority.

A land use map of New Haven is included in the Appendix.

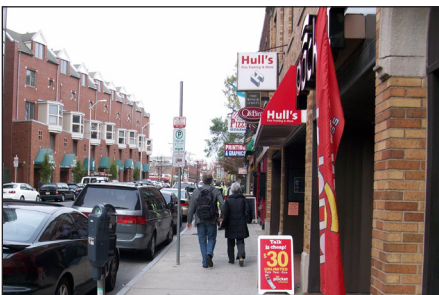

Mixed use, downtown street, New Haven



Residential street, New Haven



Central business district, New Haven

how?
CREATING COMPLETE STREETS

chapter 7

7. How to Create Complete Streets

A variety of design treatments can be employed to create Complete Streets, each with varying degrees of community involvement, engineering and education necessary for successful implementation. Following is a list of treatments that are most likely to be applicable to New Haven streets. This manual presents them as options in the form of a “toolbox”, and it is expected that all roadway projects - whether initiated by the city, state or community groups - will employ the toolbox as a starting point. The toolbox does not prescribe which specific tools must be used in a given situation. Instead, it offers users guidance in determining which elements are most appropriate and feasible given the context and goals of the particular project, and given the Complete Streets policy and guiding principles outlined in the manual.

The Decision Matrix presented later in this chapter provides additional guidance for this decision-making process and provides an important check for evaluating inclusion of Complete Street elements in every project undertaken by the City of New Haven that affects the City Right-of-Way.



Orange Street, New Haven

7.1 COMPLETE STREETS TOOLBOX

7.1.1 Sidewalk Widening

ADA standards specify a minimum of 5 feet clear path width to accommodate two wheelchairs passing each other. Generally, sidewalks should be as wide as possible to accommodate foot traffic, given available street width. No existing sidewalks should be reduced in the course of street widening projects. Opportunities for widening sidewalks and narrowing streets should be considered whenever roads are reconstructed.



Chapel Street, New Haven

7.1.2 ADA Compliant Curb Ramps

Access for all users is an important part of any Complete Street. Per ADA guidelines, wheelchair ramps with detectable warning strips should be installed wherever a sidewalk crosses a curb, and existing ramps should be upgraded to meet current ADA guidelines.



Curb ramp, New Haven

7.1.3 Street Furniture

Functional and aesthetically pleasing street furniture contributes to a pleasant walking environment and supports the use of the street as a public space. Examples of street furniture include benches, lighting, bike racks and shelters, bus stop shelters, newsstands, informational signs and kiosks, and waste receptacles. Proper design and application is essential to maintain functionality and accessibility of the sidewalk.

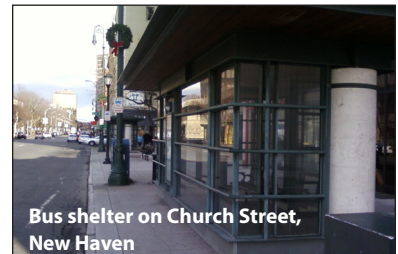

Bus shelter on Church Street,
New Haven

7.1.4 Crosswalks

Crosswalks should generally be installed at controlled intersections and should be placed to minimize crossing distances and conflicts between pedestrians and vehicles. Midblock crosswalks on arterials and collector roads will be considered as needed, subject to traffic studies and engineering judgment. In most cases, midblock crosswalks should be installed in conjunction with other tools such as bump-outs. High visibility crosswalks (also known as International Style) are preferred over designs consisting of two parallel lines as volumes warrant.



Crosswalk with in-road pedestrian
sign, New Haven

7.1.5 Tree Belt Enhancements

Street trees and other landscaping not only provide aesthetic enhancements to a street, but also help mitigate air pollution, provide shade and lower temperatures, and provide opportunities for better stormwater control. Proper maintenance is key to the success of planted areas. Opportunities for widening tree belts and narrowing streets should be considered whenever roads are reconstructed.

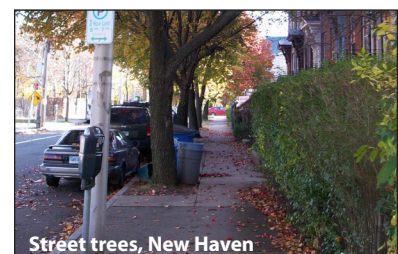

Street trees, New Haven

7.1.6 Sidewalk Surface Treatments

Sidewalks are typically surfaced in standard concrete, but alternative materials such as brick or stone pavers or even tinted concrete can be used for aesthetic enhancements that contribute to a pleasant walking environment, as well as to improve stormwater control through permeability. Proper maintenance is essential, as some materials, particularly brick pavers, can lift or settle over time and create tripping hazards or obstacles for wheelchairs.



7.1.7 Roadway Surface Treatments

Roadways are typically paved in asphalt or concrete. However, other surface treatments such as pavers or stamped/imprinted concrete or asphalt may be used in certain locations to enhance aesthetic character, improve stormwater control through permeability and/or delineate space for various street users. Maintenance is an important consideration for any unconventional surface treatment.

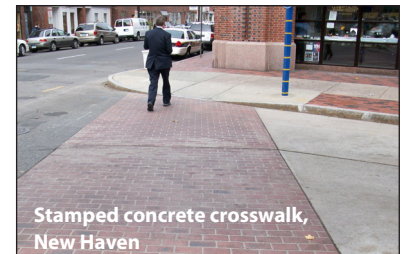

7.1.8 Pavement Markings

A variety of pavement markings can be employed to improve street safety and functionality for all road users. Some examples include directional arrows, school zone warning signs, and stop bars. Several types of markings are discussed in more detail in this toolbox, including crosswalks (above) and road narrowing and bike lanes (below). Roadway pavement markings typically follow guidelines set forth in the Manual on Uniform Traffic Control Devices (MUTCD), and any "pilot" markings proposed are subject to the judgment of the City Engineer.



7.1.9 Speed Humps

A speed hump is a raised area in the roadway pavement surface that can help reduce speeds. Speed humps are most effective when used in combination with other traffic calming/speed reducing measures, and they are not suitable for all locations. Also, they require strong community support to offset negative impacts such as noise.



7.1.10 Refuge Islands

Islands enhance pedestrian safety and accessibility on streets with two-way traffic by reducing crossing distances and providing refuge for pedestrians to cross one direction of traffic at a time. They can also serve as a traffic calming tool by narrowing the roadway at intersections, forcing vehicles to move more slowly.



7.1.11 Bump-outs/Chokers

Bump-outs (also known as curb extensions or neckdowns) are an expansion of the curb line into the adjacent roadway (typically a parking lane) either at a corner or mid-block. Two bump-outs can be located on either side of a street to create a choker. Bump-outs have many potential benefits including the following:

- Narrowing the roadway both physically and visually
- Slowing turning vehicles
- Shortening crossing distance and reducing potential conflicts between vehicles and pedestrians
- Making pedestrians more visible to drivers
- Highlighting the presence of the crosswalk and discouraging illegal parking within crosswalk
- Providing additional pedestrian space, which can help reduce crowding at bus stops and for queueing at crossings, as well as location for street furniture
- Can discourage illegal parking in front of hydrants
- Can discourage truck turns onto local streets



Bump-outs with bike racks, downtown New Haven

7.1.12 Chicanes

A chicane shifts traffic from one side of the street to the other through the use of staggered curb extensions or a serpentine roadway alignment. Chicanes discourage or make it impossible for drivers to drive in a straight line, which can reduce vehicular speeds. Chicanes may also be created by staggering on-street parking. Potential impacts on drainage, street sweeping, and snow clearance must be thoroughly addressed in any chicane design.



Chicane on Vista Terrace, New Haven

7.1.13 Diverters

Diverters are physical barriers that redirect or obstruct motor vehicle traffic with the purpose of reducing vehicle speeds and cut-through traffic on local streets. Diverters must be designed with particular consideration for drainage and emergency vehicle access, and designs should not impede bicycle circulation.

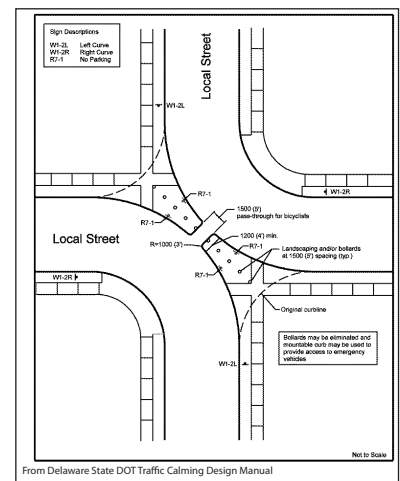

Diagonal diverter

7.1.14 Road Closures

A road closure is a physical barrier placed at one end of a street with the purpose of eliminating cut-through traffic. A partial closure may also be used to discourage through traffic by prohibiting entry or exit in one direction on a two-way street. In either case, provision should be made for bicycle circulation, as well as emergency vehicle access which can be accommodated with mountable curbs.

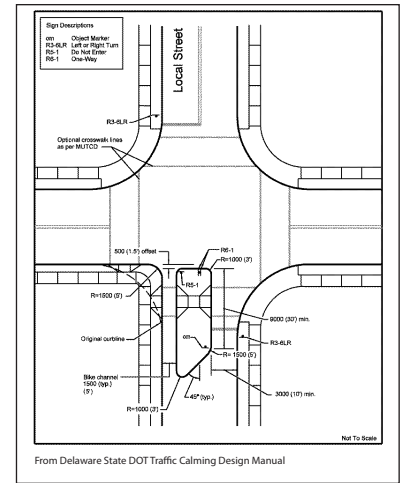

7.1.15 Traffic Patterns

Traffic patterns are sometimes changed to ease vehicle traffic flow, but they can also be adjusted to provide safety improvements or increase transportation mode options. Some examples include conversion of a street from one-way to two-way operation, or installation of center left turn lanes. When warranted, traffic patterns can also be altered by installation of a signal or other traffic control device. When accompanied by a new crosswalk, such devices increase circulation options and safety for pedestrians. Multi-leg or skewed angle intersections should be redesigned (to the extent possible) to simplify operations and reduce conflicts. Any changes in traffic patterns require careful assessment of potential impacts on all road users, and proposed designs are subject to the professional judgment of the City Engineer. Redesigning complicated intersections, however, should be done carefully to avoid increasing vehicle speeds and/or destroying the unique geometries that are part of the history and charm of a neighborhood.

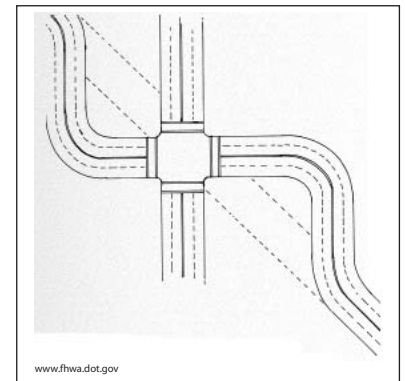

Realignment of skewed intersection

7.1.16 Bike Routes

All roads except for limited access highways are available for bicycle use. Vehicle drivers are legally required to share the road with bicycles, and cyclists have a legal responsibility to obey all traffic regulations. Dedicated bicycle facilities generally fall into one of the three categories below:

Shared use paths (Class 1) provide separate travel ways designated for non-motorized uses. Bicycles, pedestrians, skaters, and in some cases even cross-country skiers may use these paths for commuting or recreational purposes without conflicts with vehicles. A local example is the Farmington Canal Greenway.

On-road bike lanes (Class 2) are dedicated lanes separated from vehicle lanes with pavement markings. Usually signage is used to further enhance awareness. Class 2 bike lanes can be used to provide dedicated bicycle space on streets with high volumes or bicycle traffic, or as a way of encouraging cyclists to use certain routes. Bike lanes can be combined with other pavement markings as part of an overall street narrowing effort, though bike lanes should not be considered as a traffic calming measure in and of themselves. Five feet is the typical minimum width for a bike lane, though four feet may be acceptable in certain locations without on-street parking or curbs, subject to the judgment of the City Engineer.

Contra-Flow Bicycle Lanes: New Haven has a complex network of one-way streets that present a connectivity and safety challenge to cyclists. The detours that are required when navigating a one way system often force cyclists onto routes that are more stressful and less safe. As a result, many cyclists will choose to ignore one-way restrictions and ride against traffic, a behavior that is unsafe, but will remain uncontrollable as long as the street network is not adequately serving the needs of cyclists

Contra-flow bike lanes, or a designated facility marked to allow bicyclists to travel against the flow of traffic on a one-way street, offer a solution for accommodating cyclists on certain streets where the following conditions are met:

- There is a clear “desire line” for bicycle travel, usually indicated by a high level of wrong-way riding;
- Automobile traffic volumes are low;
- Automobile speeds are low



Farmington Canal Greenway



Orange Street bike lane, New Haven

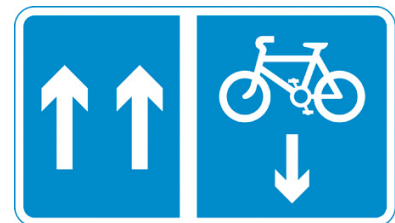

7.1.16 Bike Routes, continued

Bicycle routes (Class 3) are roadways that are designated for bicycle use but contain no dedicated bike lane or pavement markings for bicycles. Signage is usually used to remind drivers of the presence of bicycles.

The City of New Haven aspires to create a connected network of bicycle routes, and where geometry allows, on-road bike lanes should be added as part of roadway construction projects.



Whitney Avenue bike route, New Haven

7.1.18 Bike Boulevards

A bicycle boulevard is a shared roadway where the bicycle, or any other human-powered vehicle, is the primary design vehicle. Bicycle boulevards should be considered as a potential improvement on residential streets or neighborhood streets where high-volume, high-speed motor vehicle traffic is undesirable.



7.1.19 Bike Parking

Bicycle parking can be broken into four (4) categories. These are short term public parking, long-term public parking, short term private parking, and long-term private parking. These four areas are described in greater detail in Appendix (X).



Bike parking at Union Station, New Haven

7.1.20 Shared Lane Markings

Shared lane markings (“Sharrows”) are arrows painted on the roadway, usually in combination with signage, to alert drivers to the presence of bicycles on roads that have no dedicated bicycle lanes (usually Class 3 bike routes). They are often used in locations where a bike lane is desired but not feasible due to roadway width constraints.



Sharrows in Hilliard, Ohio

7.1.21 Bike Signage

Bicyclists use all types of streets, and signs can be used on any type of roadway to increase awareness of bicycle use. On Class 2 and 3 routes, “Bike Lane” or “Bike Route” signs are typically used. On other roads, signs with messages such as “Share the Road” can improve awareness. Additionally, signage can be used to direct cyclists on where and how to ride, thereby reducing conflicts with vehicles and improving safety. Current available options for roadway signage typically come from the Manual on Uniform Traffic Control Devices (MUTCD), and any “pilot” signage proposed is subject to the judgment of the City Engineer.

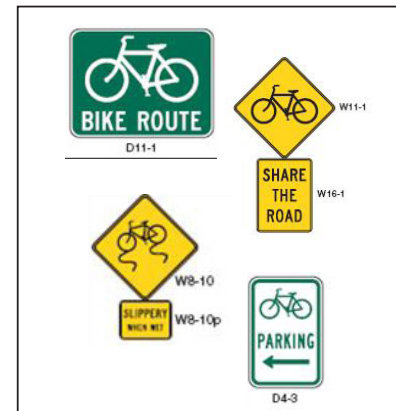

MUTCD bike signage

7.1.22 Roadway Narrowing

In general, narrower roads result in lower vehicle speeds. The width of a roadway sends an implicit message to drivers about how they should drive – wide streets encourage high speeds, while narrower roads force vehicles to move more slowly to stay in their lane and prepare for potential conflicts. Narrow streets are also easier and safer for pedestrians to cross. Roadway narrowing is a relatively easy design treatment, as it can often be implemented with pavement markings. Below are recommended lane widths for various roadway types, though lane width requirements for any given street are subject to the professional judgment of the City Engineer.

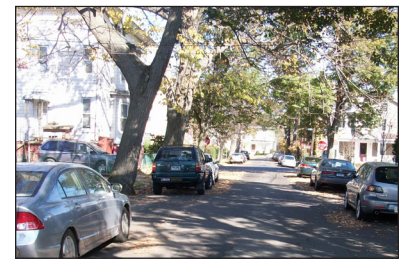

Narrow street, New Haven



Arterials and Collectors

Roadways classified as arterials or collectors should have maximum 10-11' travel lanes. This width does not include on-street bike lanes or shoulders. Designated bike routes (without bike lanes) or streets with heavy bicycle traffic should have a minimum 4' paved shoulder rather than a widened vehicle travel lane. Desired travel speed is also a factor; roads with posted speed limits below 35 mph should have lane widths at the lower end of the range.



Local Roads

Two-way local roads often consist of a wide, “shared” lane with no center stripe. These streets generally operate in one of two ways:

- The shared lane is wide enough to accommodate two vehicles traveling in opposite directions at the posted speed limit. The shared lane should be 18-20' wide.
- The shared lane is wide enough to accommodate both vehicles, but a narrower width forces the vehicles to slow down before passing each other, or one vehicle to yield to the other. This is sometimes called a “yield street.” The shared lane should be 14-18' wide.

Local roads in residential neighborhoods should be as narrow as possible with “yield street” operation unless the need for free flow of traffic can be justified.

7.1.23 Mini Roundabouts

A mini roundabout is a round island at the center of an intersection. It is best suited to low-volume streets, with the purpose of reducing speeds and intersection conflicts, thereby reducing accidents. Mini roundabouts also provide opportunity for landscaping and other aesthetic enhancements, and they can be installed without changes to adjacent curbs.



Woodward Avenue, New Haven

7.1.24 Roundabouts

A roundabout is an intersection with one-way, counter-clockwise traffic around a central circle in which traffic entering the circle yields to traffic already inside. The main benefit of roundabouts is the elimination of left turn conflicts, which are a primary cause of accidents. Roundabouts can improve pedestrian safety if designed correctly, but care must be taken in the design to maintain pedestrian routes that are direct and easily accessible.



Woodward Avenue, New Haven

7.2 OTHER COMPLETE STREETS TOOLS

Many other design treatments have been successfully employed around the country and the world in the creation of Complete Streets. This manual is not intended to provide an exhaustive list of all potential designs. A good list of resources for additional information about Complete Streets and potential design treatments can be found on the website of the American Planning Association at the following link: <http://planning.org/research/streets/resources.htm>.

7.3 WHAT NOT TO DO

Sometimes street design treatments intended to solve a traffic or safety problem have unintended impacts. An example is the conversion of two-way streets into one-way operation. Despite the benefits of reducing some turning conflicts and cut-through traffic, one-way streets run at cross purposes with most of the Complete Streets guiding principles. As a general principle, conversion from two-way to one-way operation should be avoided, and conversion from one-way to two-way operation should be considered when appropriate and feasible (see “Traffic Patterns” section 7.1.15 above).

Signage: New Haven street designs should embrace the principle that quality road design greatly reduces the need for instructional signage for drivers. A properly designed roadway will elicit the proper behavior from drivers without cluttering the right-of-way with unattractive signage. Road design is an exercise in behavioral engineering and the City of New Haven commits to harnessing this knowledge to improve sharing and compliance to road rules by all users of the street. This may include minimizing unwarranted stop signs or multiple regulatory and/or warning signs placed closely together and minimized usage of center lane striping on local streets with preference given to shared lanes that encourage more careful driving driving (see “Roadway Narrowing” section 7.1.22 above).

Finally, street designs should solve problems rather than merely shifting traffic or other negative impacts from one street to another or one neighborhood to another. Particular care should be taken to avoid negative impacts on federally protected populations.



measurement
MAKING IT COUNT

chapter 8

8. Measurement: Making it Count

The continued measurement and evaluation of the overall use of the transportation system is an essential part of creating Complete Streets. This entails determining who is using the street network in New Haven, how they are using it, how usage changes over time, and establishing the adequacy of the street network as it pertains to each of the major modes of transportation utilized within the city of New Haven.

8.1 WHY MEASURE?

The purpose of the Complete Streets Design Manual is to ensure that all streets are designed to provide a safe and comfortable environment for all roadway users. It is essential, therefore, that the quality of the transportation system, and the users' experiences of that system, are measured and evaluated continually to ensure that any changes and improvements facilitate the achievement of the program's objectives. Additionally, by measuring the effects of each roadway improvement, we can fine tune our approach to street design while providing residents with quantifiable results. Specifically, the measurement and evaluation program is necessary in order to:

- Provide baseline data to determine trends, evaluate effects, determine where improvements are most needed, and provide the information necessary for grant applications
- Determine the overall level of travel demand by mode
- Determine changes in travel speed brought about by changes to the roadway
- Determine the benefits of different types of transportation improvements
- Calculate performance measures for each travel mode including walking, cycling, transit, and driving
- Assist in the data collection necessary for the continued application for, and receiving of, state and federal grants
- Assist in the allocation of funding for transportation projects



Transit use in downtown New Haven



Pedestrians and cyclists in downtown New Haven

8.2 WHO TO MEASURE?

Complete Streets safely and comfortably accommodate all roadway users. In order to move toward a transportation system where all users count, all users must first be counted. Until recently however, data collection for transportation planning has focused largely on counting the number of automobiles on a roadway and, to a lesser extent, the number of transit riders on a particular route. Many cities like New Haven, despite having a large number of cyclists, transit users and pedestrians, are “flying blind” when it comes to planning for these groups. While estimates may be available through the data compiled by the U.S. Census, travel behavior as it pertains to cyclists, transit users and pedestrians remains largely unknown. Even the most detailed census data, the National Household Travel Survey (NHTS) is obtained infrequently and often at irregular intervals.

Because of the need for empirical data to measure the success of roadway projects, the City of New Haven will undertake the regular and continued enumeration of all roadway users, including pedestrians, bicyclists, bus and train riders, motorists, and multimodal users. By ascertaining the travel demand and travel behavior of all roadway users, the city will be able to serve each travel mode efficiently, effectively, and equitably. Particular attention should be given to how different modes of transportation may be used together for a single trip or series of trips.

8.3 WHAT TO MEASURE?

Measurement and evaluation of the transportation system should focus on the collection of both objective and subjective data.

8.3.1 Objective Data

Objective data includes the volume of users, the number and rate of traffic accidents, travel speeds, and the demographics of roadway users. Objective data may be obtained using a variety of methods and sources including manual counts, automated counts, user surveys, and accident reports. In order to ensure that all roadway users are counted, it should be a requirement that pedestrians, cyclists, and transit users are counted whenever automobile counts are undertaken. In other words, all traffic counts must count all traffic.



Pedestrians at State Street Station, New Haven

In addition to collecting data, it is important to make use of objective performance measures for each major mode of transportation, including automobile, bicycle, pedestrian, transit and multimodal levels of service (LOS). Much of the current imbalance in our transportation system has come about in part as a result of overreliance on automobile LOS as a metric for the quality of a given roadway segment, intersection,

or corridor. Recognizing that all transportation modes must be provided for, the five measures mentioned above should be reported in the course of all major studies and projects, allowing for a comprehensive and thorough summary of the quality of the transportation network.

8.3.2 Subjective Data

Recognizing that users' experiences of the transportation system cannot always be captured by objective measures, user surveys will be administered at regular intervals and integrated with the city's transportation planning and engineering projects. Surveys can be administered in a variety of different ways including intercept surveys, take-home surveys and web-based surveys. This subjective data focuses on the attitudes and beliefs of those individuals using the transportation system. . . .



8.4 WHEN & WHERE TO MEASURE

As mentioned above, a large amount of data is generally obtained at irregular intervals during the course of transportation plans and studies. This data provides important snapshots of how the transportation system is used; however, for measurement and evaluation of the transportation network to be maximally effective, it must be standardized and undertaken at regular intervals. Below are data collection guidelines for the measurement and evaluation program:

- Counts and user surveys should be done annually.
- Counts should reflect a typical weekday and typical weekend with particular emphasis on peak periods of travel demand.
- A set of permanent count locations should be established so that trends and changes may be observed and measured.
- Because of the large student population in New Haven, counts should be taken when both the universities and New Haven public schools are in session.
- Counts should not be undertaken during inclement weather or during festivals or special events.
- User surveys should be kept relatively constant so that results from different survey years may be compared. While new survey questions can and should be introduced, this should be done carefully and sparingly.

In order to understand the effects and benefits of improvements made to the transportation system, it is essential to conduct before and after studies, obtaining data on volumes, modal split, travel speed, and accident experience. By doing this, we can determine which improvements are maximally effective, discontinue improvements that are ineffective, and demonstrate the overall return on investment to taxpayers.

Subjective Data

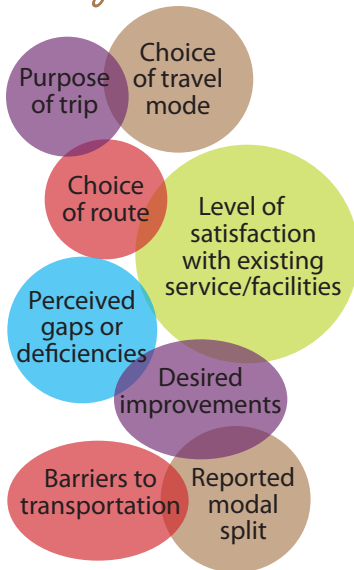

funding,
FUTURE STRATEGY &
review process

chapter 9

9. Funding, Future Strategy & Review Process

9.1 FUNDING

The Complete Streets Committee recognizes that local funding sources are limited relative to our citywide mission. However, our funding strategy going forward is layered and includes guidance for the more appropriate use of existing funding streams and capital programs of the city, state and federal governments. The new design details will be used as well with private developers on major projects and with the state with transportation improvements.

9.1.1 City of New Haven

The City of New Haven administers the following ten programs which relate specifically to Complete Streets and transportation investments. For each program, the City is responsible to screen individual projects for consistency with the policies and principles of the Complete Streets Design Manual, as well as the Decision Matrix detailed in Chapter 7.

- Sidewalk Construction and Repair
- Pavement Management
- Street Reconstruction
- Major Sidewalk Replacement
- Traffic Calming Initiative
- Neighborhood Commercial Public Improvements
- Traffic Control Signs and Markings
- Transportation Enhancements
- Traffic Signals
- School Construction



Bike lane installation, New Haven

In the 2010 budget, the city administration took the initiative to incorporate complete streets language into capital budget projects. This change is an important indication that the 'sea change' in the policies and procedures of road building in the City of New Haven is being fully integrated into the way the city does business. Complete Streets is not 'an addition' to how projects are managed, but rather an integral part of these projects.

While each program is mainly focused on traditional state-of-good repair investments, the Decision Matrix will serve as a guide toward the seamless integration of the Complete Streets Design Manual with the general run of government. To better ensure that each of these programs is consistent with the manual, the managing departments will coordinate their work on a monthly basis.

In addition, the City Plan Department administers the site plan review process. Site plan review is required to aid the City in determining the conformity of a proposed building, use, or structure with specific provisions of the Zoning Ordinance as adopted by the Board of Aldermen. As part of this review, City Plan reviews a submission against the Engineer's typical project details, which are now updated with Complete Streets guidelines. Site plan review applies to the following projects:

- All variance, special permit and special exception applications when required as a condition of approval
- Any new construction or change in an existing use for three or more dwelling units, whether in a single structure or in multiple structures, whether in new structures or converted space
- Any new construction or change in an existing use involving 5,000 or more square feet of gross building area
- Any new construction or change in an existing use involving ten or more parking spaces
- Any use involving a drive up service window or facility
- Other uses and applications as specified in the Zoning Ordinance



Public meeting, CT Statewide Bicycle and Pedestrian Plan

9.1.2 State of Connecticut / South Central Regional Council of Governments

The City works closely with the Connecticut Department of Transportation and the South Central Regional Council of Governments on the planning and implementation of state and federally funded transportation projects in the City. For these projects, the City will work with project planners and engineers to review specific projects from a Complete Streets perspective. While the City generally must work within the parameters of these larger programs, it is the responsibility of City staff to (1) brief the State's project managers on the Complete Streets program; (2) select projects which enhance bicycle and pedestrian access / safety; and (3) seek design exceptions and waivers as necessary to create a Complete Street.

For general maintenance work, the City will arrange an annual review meeting with the Connecticut District III and IIIA District Engineers to review work plans on state highways and seek to enhance bicycle and pedestrian safety, reduce travel speed and improve safety at key intersections.

9.2 FUTURE STRATEGY

Often, projects that affect the ROW do not involve road reconstruction but are disruptive and result in reestablishing much of the road. Such is the case with major sewer or drain replacement projects that are managed by the GNHWPCA or related work that DOT is doing to improve its roadway. As these projects come forward, it is often a good time to incorporate Complete Street criteria as part of the project. In some cases, it may be necessary to provide some supplemental funds that would allow this to happen. In doing so, savings are realized. In most cases, mobilization costs, paving costs, and traffic control costs are made part of the eligible work which would otherwise be tagged to a separate project. Leveraging other project work to satisfy needs of the complete streets work can be considered when reviewing plans involving other work that disturbs the city ROW.

9.2.1 Overview

The City's Comprehensive Plan, Sustainable Transportation Framework and the State's Long Range Transportation Plan provide the foundation for long-term investments. These plans provide guidance for the more specific implementation efforts found in municipal development plans, development agreements, neighborhood-based and commercial district improvement plans and other programs. City staff and the Board of Aldermen are responsible for the review of these more specific plans to ensure consistency with the Complete Streets mission.

Complete Streets Guidance

- Complete Streets Design Manual
- Connecticut Long Range Transportation Plan
- New Haven Comprehensive Plan
- New Haven Greenways and Trails Plan
- New Haven Sustainable Transportation Framework

Implementation Plans and Projects

- City of New Haven Initiatives
- Community Requests
- CTDOT District III and IIIA Operating and Capital Programs
- Elm City Cycling Bike Plan
- Municipal Development Plans and Development Agreements
- Safe Routes to Schools Master Plans
- Neighborhood Bike, Pedestrian and Traffic Calming Plans

In addition, the City will work closely with the South Central Regional Council of Governments to design and schedule Complete Streets projects as part of the regional

work program. This includes both planning projects (“urban work program”) as well as the regional plan for federal transportation funds, known as the Transportation Improvement Program (TIP). The City will aggressively pursue funding through smaller programs, including the Transportation Enhancement Program (for bike and public transit projects) and the Safe Routes to School Program for school-based investments.

Reauthorization of SAFETEA-LU, the federal transportation authorization bill, will define the future of these programs, so the City has joined T4America, a nationwide advocacy group that is lobbying the federal government for progressive changes to federal transportation funding programs. Finally, the City will work closely with CT DOT on state projects that fulfill the mandate of the state’s Complete Streets legislation (Senate Bill 735).

The City of New Haven’s new Office of Sustainability has been charged with developing a traffic demand management strategy for the City of New Haven. This presents an important opportunity for the City to develop transportation related policies and incentives that support many of the guiding principle of this Complete Streets initiative.

There are important opportunities for reform of the New Haven zoning ordinances to support Complete Streets goals. For instance, with support from the City Plan Department, a new zoning category, BA-1 Neighborhood Center-Mixed Use, has been proposed. This new zone would support higher density, pedestrian-oriented neighborhood business districts by, in part, creating parking maximums. This is in contrast to the balance of zoning categories that set minimums for parking, which counterproductively encourage low-density, car-oriented development patterns.

Zoning reforms such as this can be further developed to include standards and requirements for bike parking and other transportation related improvements that will better support active transportation and transit in the City of New Haven.

Another future strategy that could be pursued to support the evolution of Complete Streets in New Haven is the creation of guidelines for applying to the Federal Highway Administration for status as a trial city for bicycle, pedestrian, and transit accommodations.

Finally, the Complete Streets Steering Committee recommends that in addition communicating these guidelines to the City Plan Commission, that the joint committee of the Police Commission and the Traffic Commission also receive this document. Immediate actions should include a presentation to the Commission members on the content of the manual. It is strongly recommended that for future appointments to this joint Commission that the Mayor prioritizes the selection of new member(s) with expertise in transportation planning or related fields.

9.2.2 Key Early Milestones

2009

October:	SCRCOG Five-Year Transportation Improvement Program										

2010

January - December:	Reauthorization of SAFETEA-LU										
February - May:	Connecticut State Legislative Session										
March - May:	New Haven Budget Process										

2011

January - June:	Connecticut State Legislative Session										
January - December:	Reauthorization of SAFETEA-LU										
March - May:	New Haven Budget Process										

9.3 ENFORCEMENT OF TRAFFIC VIOLATIONS

Enforcement efforts are a crucial component to achieving safe, complete streets in New Haven. Without the cultural expectation of compliance to traffic laws, even a perfectly engineered complete street will be insufficient.

As a result of improved communications with the New Haven Police Department about the need to increase user compliance to traffic laws, the New Haven Police Department increased the number of moving violation citations issued in 2009 by 66% over 2008 levels. Interestingly, this increased traffic enforcement contributed to an increase in narcotic seizures and the recovery of a record number of stolen firearms.

In addition, the New Haven Police Department created a Traffic Safety Hotline where citizens can report traffic violators. Cultivating the expectation that traffic laws are to be obeyed by all users is an important trend that should be supported and continued.

9.4 STREETS SMARTS EDUCATIONAL CAMPAIGN

Traffic safety education is the proper companion to any increased enforcement activity, and the award-winning “Streets Smarts” Campaign accomplishes this in a savvy and effective way. This campaign, which targets the three street user groups: walkers, cyclists and drivers, seeks to educate users on their rights and responsibilities while using the public streets. To date, the campaign has made over 6 million media impressions and over 2,000 people have signed and submitted the “Smart Driver Pledge.” In an effort to create a dynamic web presence for Street Smarts, the City of New Haven partnered with Yale University to create an engaging animated website about traffic safety: www.yale.edu/streetsmarts



Street Smarts

Smart Driver Pledge of Commitment

I understand that my driving affects the safety and livability of other people's neighborhoods, just as other people's driving affects my neighborhood. In recognition of the desire of all citizens for quality of life, safety and the pursuit of happiness, I declare PEACE in our neighborhoods and commit to using my Street Smarts everyday by:

- ▼ Driving slowly and courteously.
- ▼ Acting like a guest in all neighborhoods.
- ▼ Sharing the road with pedestrians and cyclists.
- ▼ Giving myself enough travel time so that I'm not sacrificing courtesy or safety.
- ▼ Refusing to be pressured by others' impatience to drive above the speed limit.
- ▼ Obeying the law by yielding for pedestrians in crosswalks.
- ▼ Respecting others by keeping car stereo, horn and muffler noises at a low level.
- ▼ Displaying my Street Smarts magnet on my vehicle and encouraging others to join.

NAME _____ DATE _____

ADDRESS _____

EMAIL _____

SIGNATURE _____

Please return this form to:
Mayor's Office c/o Emily Byrne
185 Church Street
New Haven, CT 06510

Your Street Smarts magnet will be sent to the above address.

Walk Smart
Bike Smart
Drive Smart
Safe Streets take Street Smarts

9.5 PERIODIC REVIEW PROCESS

On an annual basis, the City of New Haven will review roadway projects that have been completed or are in the process of being completed to help determine the success of the Complete Streets initiative. The City Engineer will include this information in its Annual Report which is submitted to the Board of Alderman and the Mayor's Office. The report will include information about particular projects, including before and after data on volumes, accidents, multi-modal LOS, etc. (see Chapter 8 for components of before and after studies). The report will also include an evaluation of lessons learned and things that should be changed. It will also provide data on public requests for projects, public involvement in the planning process, and public response to completed projects.

In addition to the BOA report, the City of New Haven will convene an annual meeting (likely around January-February) with stakeholders including city agency staff, police representatives, BOA members, and other interested parties to discuss Complete Streets and plan for the future of the program.

Notes

1. American Planning Association. <http://planning.org/research/streets/>
2. Census 2000 Summary File 3 (SF 3) - Sample Data, DP-4. Profile of Selected Housing Characteristics: 2000.
3. National Complete Streets Coalition. <http://www.completestreets.org/complete-streets-fundamentals/complete-streets-faq/>
4. New York City Department of Transportation, Street Design Manual, Section 1.3, pp. 30-33.

Appendices

- Appendix A: Project Request Form
- Appendix B: Roadway Classification Map
- Appendix C: Land Use Map
- Appendix D: Standard Details
- Appendix E: Decision Matrix
- Appendix F: Bicycle Boulevards
- Appendix G: Bicycle Parking
- Appendix H: Tree Policies

APPENDIX A: PROJECT REQUEST FORM

PROJECT INFO

Project Name
Project Location and Limits
Contact
Brief Description of Project
Project Impetus
Project Goals
Estimated Cost of Project (if known)
Funding Sources (if known)

CONSISTENCY WITH COMPLETE STREETS POLICY & GUIDING PRINCIPLES

Describe project context, including adjacent land uses, neighborhood character, and existing transportation system
Classification of affected street(s)

Describe how proposed project supports Guiding Principles for Complete Streets. <i>See page 16 of this Manual for descriptions of each principle.</i>
Safety and slow vehicle speeds
Connectivity
Human health
Livability
Context
Equity
Aesthetics
Economic development
Environment

APPENDIX B: ROADWAY CLASSIFICATION MAP

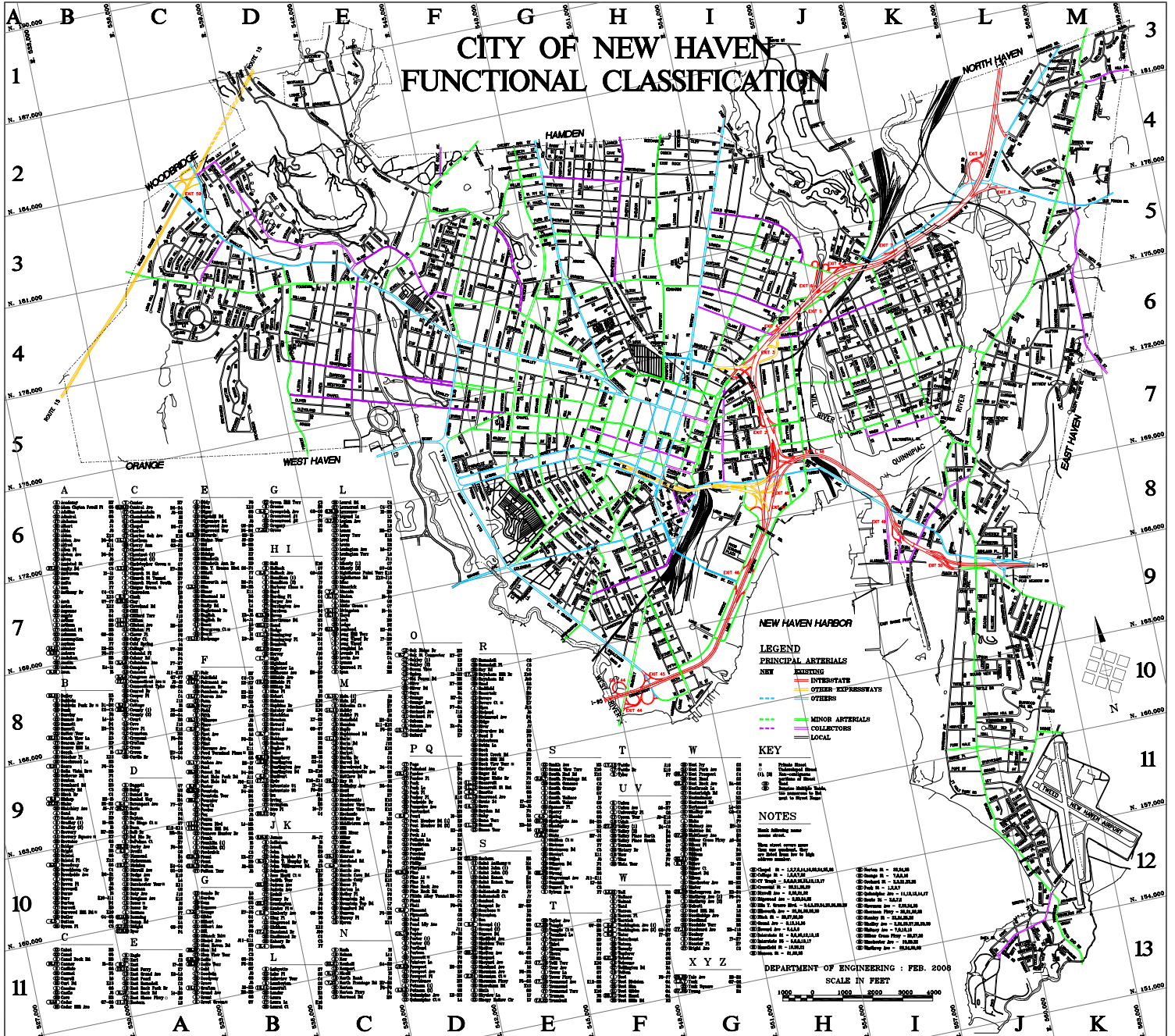

APPENDIX C: LAND USE MAP

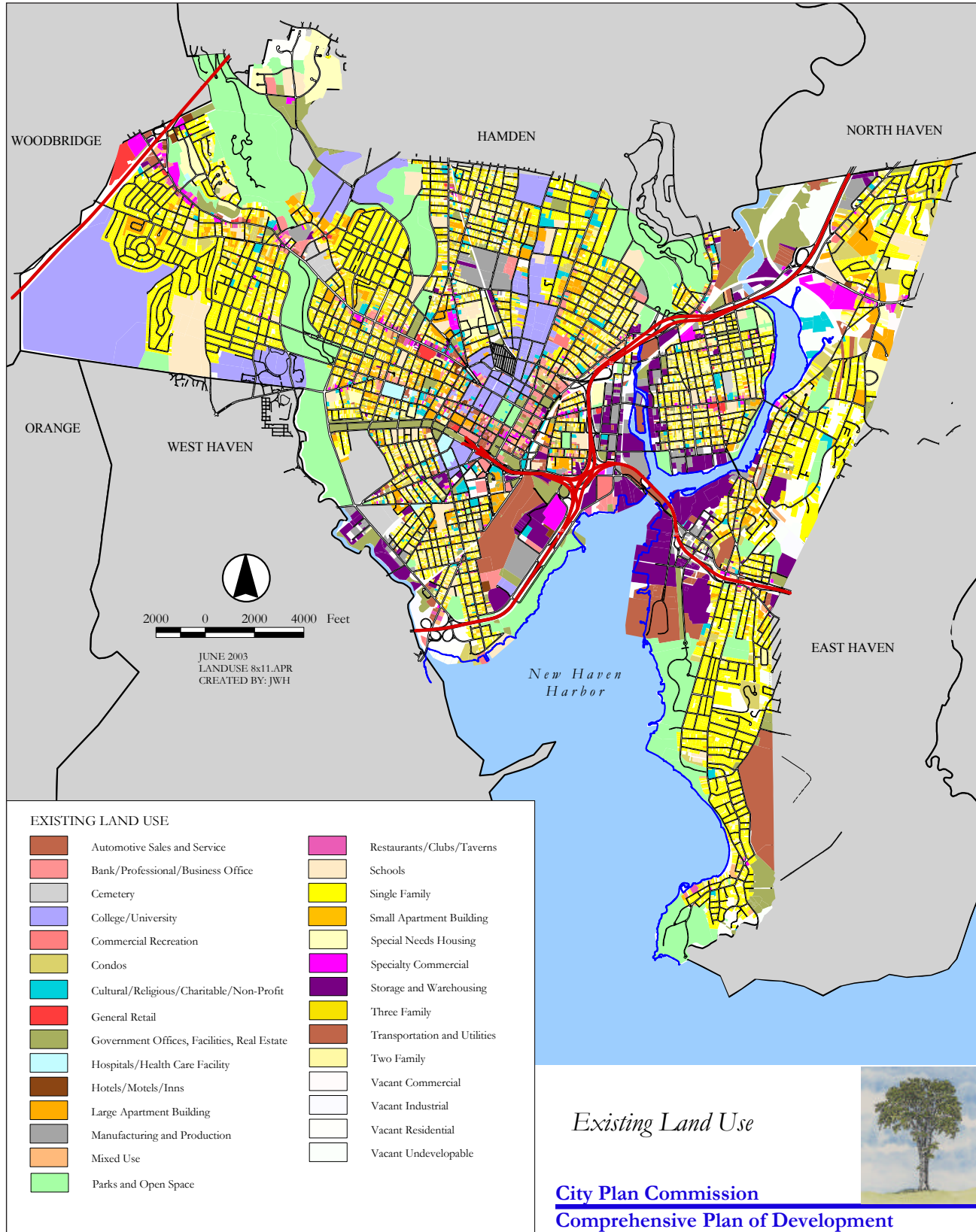

APPENDIX D: STANDARD DETAILS

Bike Lane Detail Plan

Bike Lane Traffic Marking Details

Tree Pit with Stone Dust Surface

Tree Planting with Mulch Saucer

Tree Protection Notes

Recommended Tree Types

Speed Hump Detail

Typical Roundabout Detail for Intersections Crossing Islands/Center Medians and Typical

Bumpout Detail for Intersections Center Roundabout

Typical Cross Section Mini Roundabout with Planter

Typical Cross Section

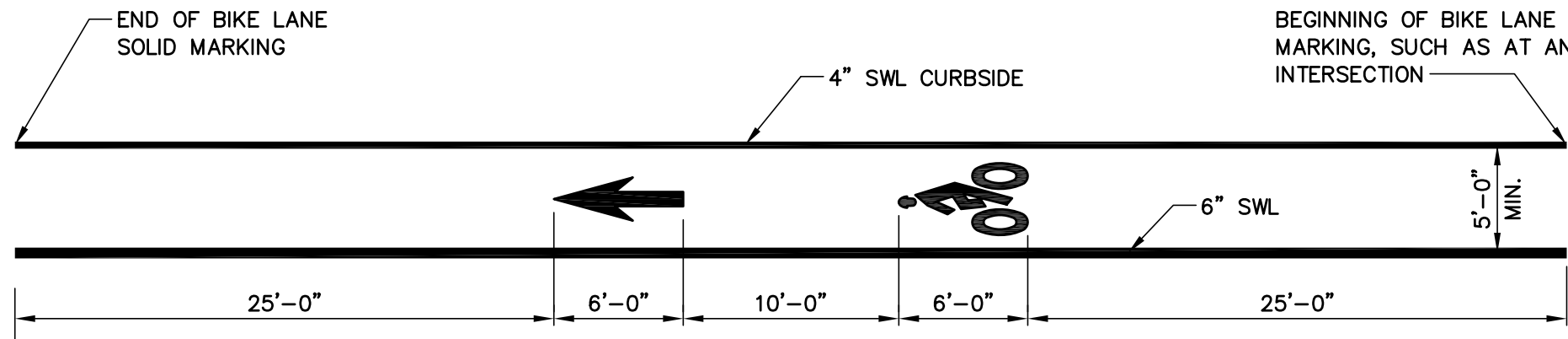

BIKE LANE MARKINGS
NOT TO SCALE

NOTE TO GRAPHICS PERSON - INSERT THE APPENDIX D FLATS INTO THE PDF AFTER THIS POINT.

NOTE:
THE BIKE LANE SYMBOL AND ARROW SHALL BE PLACED 25 FEET FROM THE BEGINNING OR END OF THE SOLID WHITE LINE IN THE BIKE LANE AT AN INTERSECTION. IF THE BIKE LANE IS CONTINUOUS THROUGH AN INTERSECTION, PLACE BIKE LANE MARKING 25 FEET PAST THE AWAY EDGE OF THE INTERSECTING STREET. SPACE INTERMEDIATE SYMBOL PAIRS AT APPROXIMATELY 300 FOOT INTERVALS. 4" SOLID WHITE LINE (SWL) MAY BE OMITTED IF BIKE LANE IS ADJACENT TO CURB.

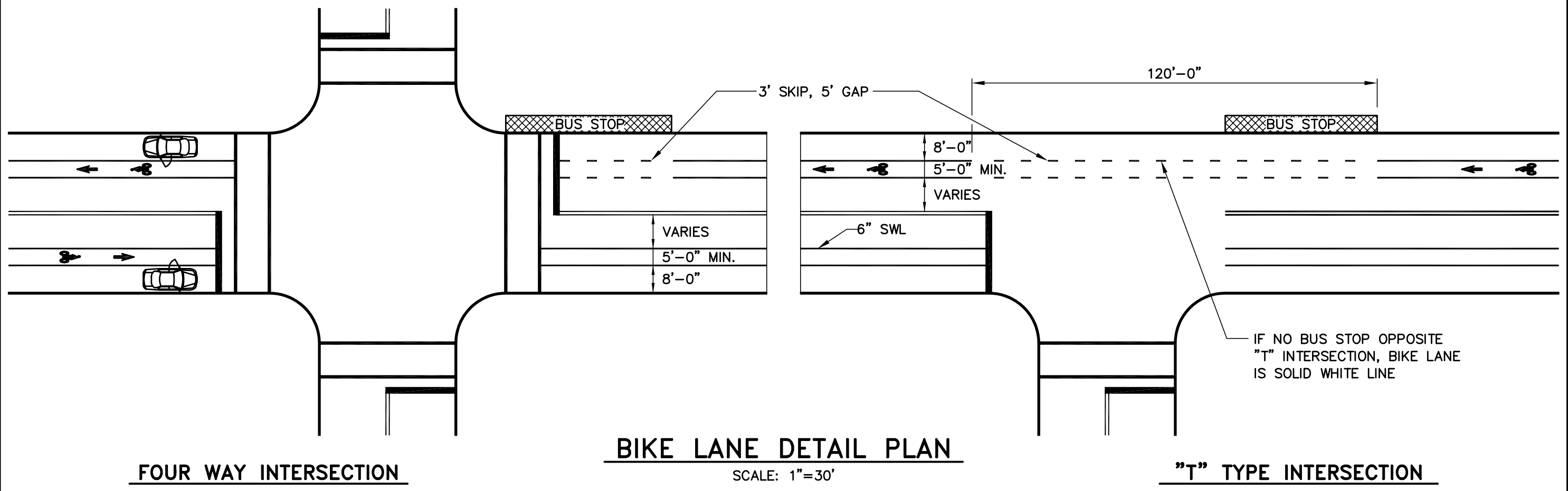

BIKE LANE DETAIL PLAN
SCALE: 1"=30'

NOTES:
1. BICYCLE PAVEMENT MARKINGS AND SIGNAGE SHALL FOLLOW MUTCD GUIDELINES AND REQUIREMENTS. SYMBOLS REPRESENT EXAMPLES APPLICABLE IN NEW HAVEN AS APPROPRIATE. SEE SHEET STD-NH-29C FOR BIKE LANE DETAILS.

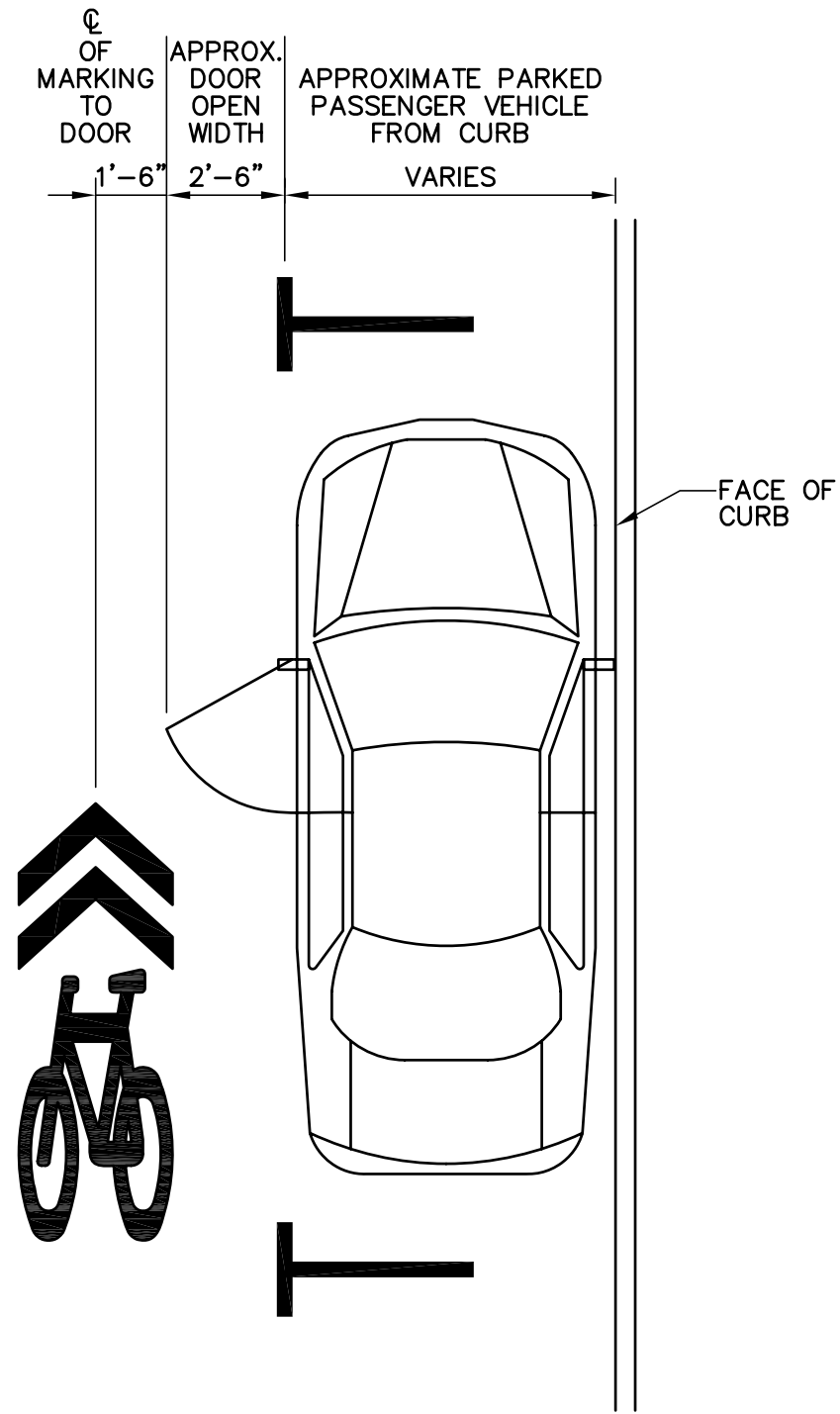

SHARED LANE MARKING DETAIL
 SCALE: $\frac{1}{4}'' = 1'-0''$

- SHARED LANE MARKING GUIDELINES:**
1. SHARROW MARKINGS SHOULD BE PLACED A MINIMUM OF 11 FEET FROM FACE OF CURB WHERE STREET PARKING IS PERMITTED. ROAD SPEED MUST BE LESS THAN 35 MPH.
 2. SHARROW SHOULD BE PLACED RIGHT AFTER AN INTERSECTION, 25 FEET BEYOND THE PEDESTRIAN CROSSING.
 3. NO SHARROW MAY BE PLACED WITHOUT PRIOR APPROVAL FROM THE CITY ENGINEER AND THE DEPARTMENT OF TRANSPORTATION, TRAFFIC AND PARKING.

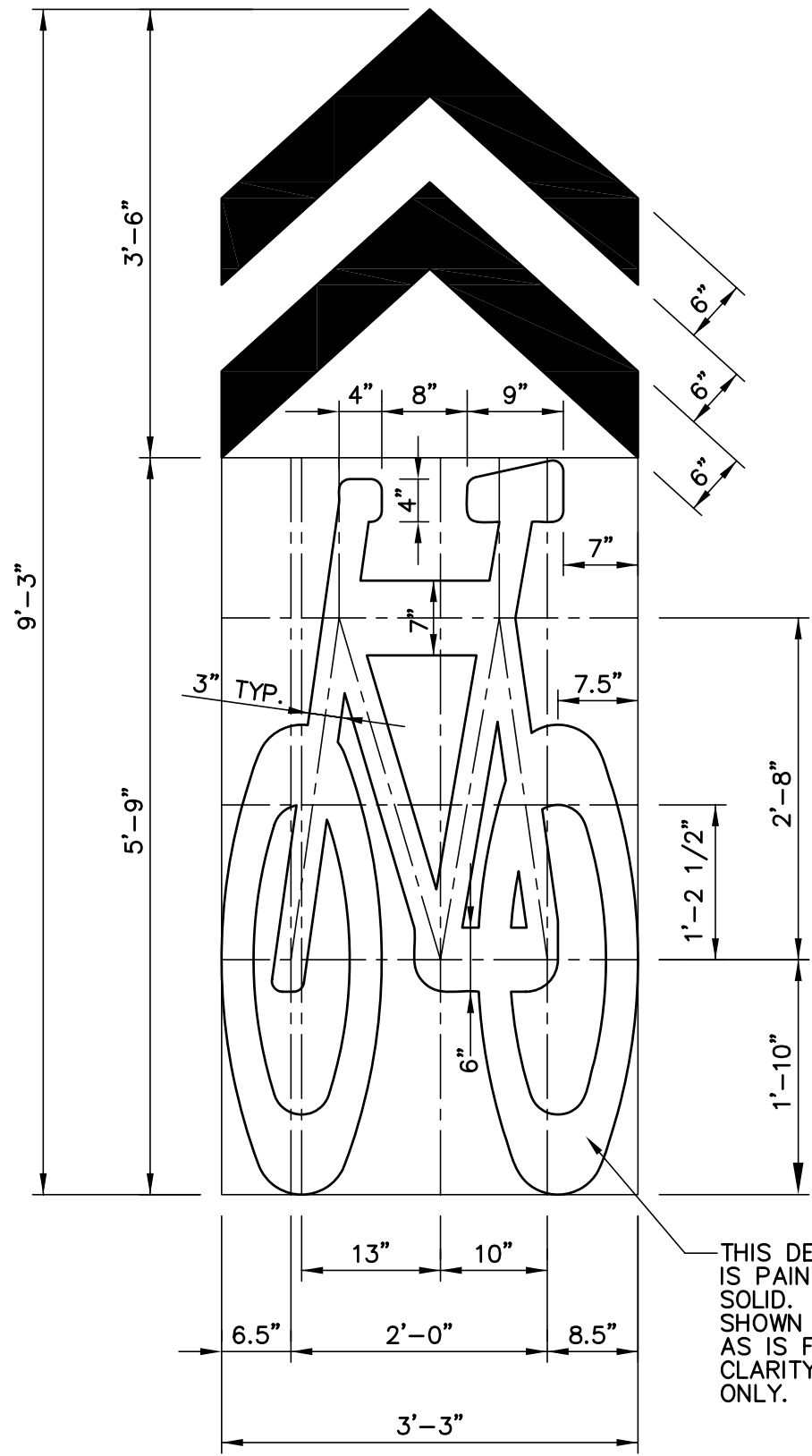

SHARED BIKE LANE SYMBOL DETAIL
 SCALE: $\frac{3}{4}'' = 1'-0''$

BIKE LANE TRAFFIC MARKING DETAILS
 SCALE: AS NOTED

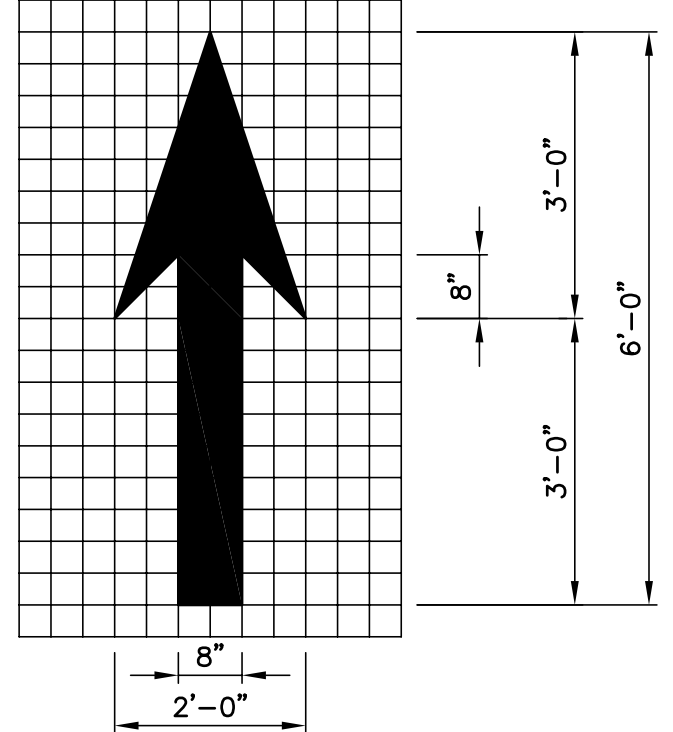

BIKE LANE ARROW DETAIL
 SCALE: $\frac{1}{2}'' = 1'-0''$

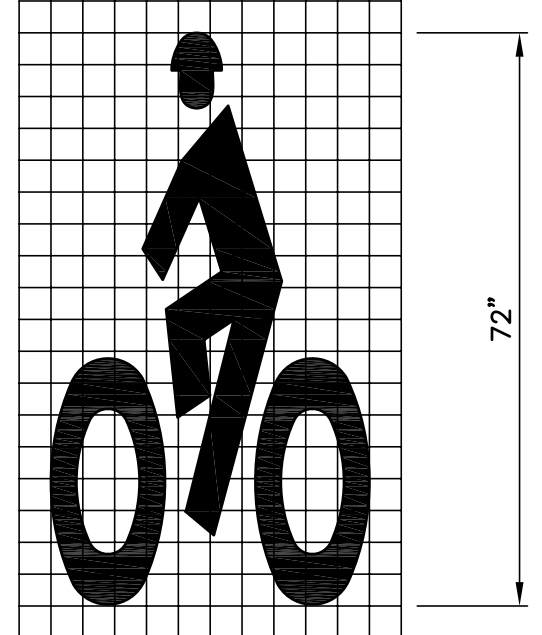

BIKE LANE ARROW DETAIL
 SCALE: $\frac{1}{2}'' = 1'-0''$

THIS DETAIL IS PAINTED SOLID. SHOWN HERE AS IS FOR CLARITY ONLY.

NOTES:

1. 4' x 4' OPENING IS MINIMUM SIZE OPENING FOR TREE PIT. IF SITE CONDITIONS AND DESIGN PERMITS, LARGER TREE PIT DIMENSIONS ARE ACCEPTABLE AND DESIRED. IF SITE CONDITIONS DO NOT PERMIT A 4' x 4' SIZE TREE PIT AND/OR REQUIRE A TREE PIT SIZE OF A DIFFERENT DIMENSION, THEN THE PROPOSED TREE PIT SIZE SHALL BE SUBMITTED TO THE LANDSCAPE ARCHITECT'S OFFICE FOR APPROVAL.
2. NO TREE PIT SHALL BE LOCATED CLOSER THAN 25' FROM A STOP SIGN AND/OR 25' FROM THE INTERSECTION OF THE BACK SIDES OF TWO SIDEWALKS (SIDE OF SIDEWALK FARTHEST AWAY FROM STREET).
3. THE PLACEMENT OF A TREE PIT SHALL IN NO CASES RESULT IN THE SIDEWALK WIDTH BEING LESS THAN 5' WIDE.
4. MARK NORTH SIDE OF THE TREE IN NURSERY AND LOCATE TO THE NORTH IN FIELD.

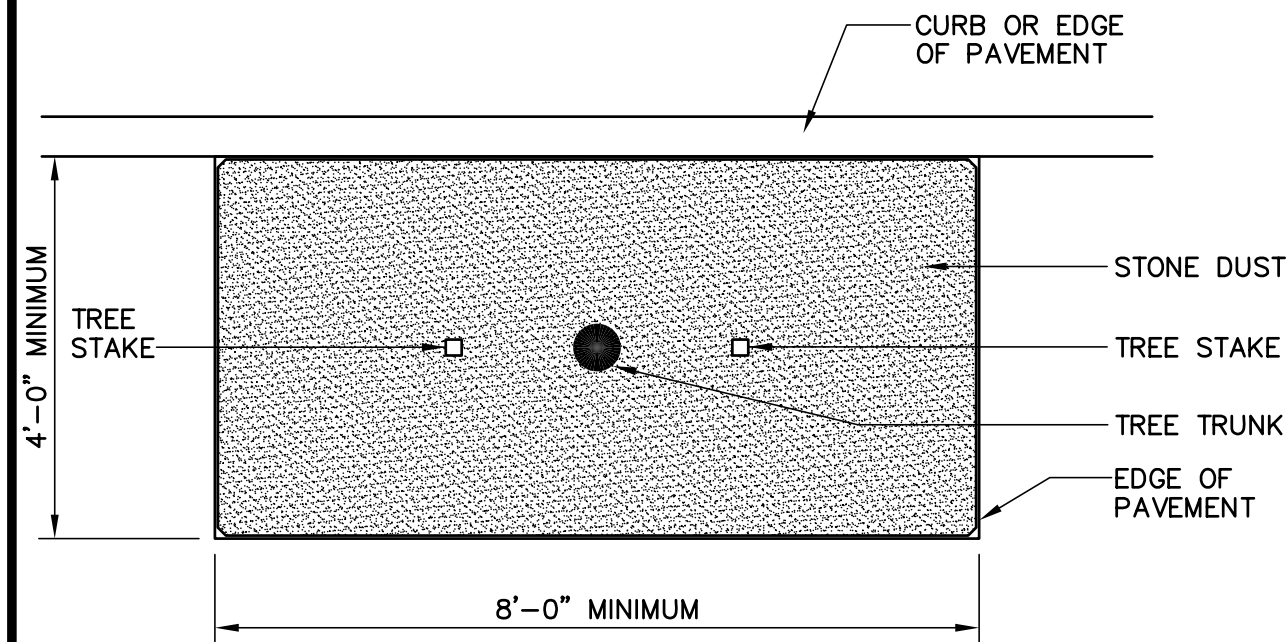

PLAN VIEW

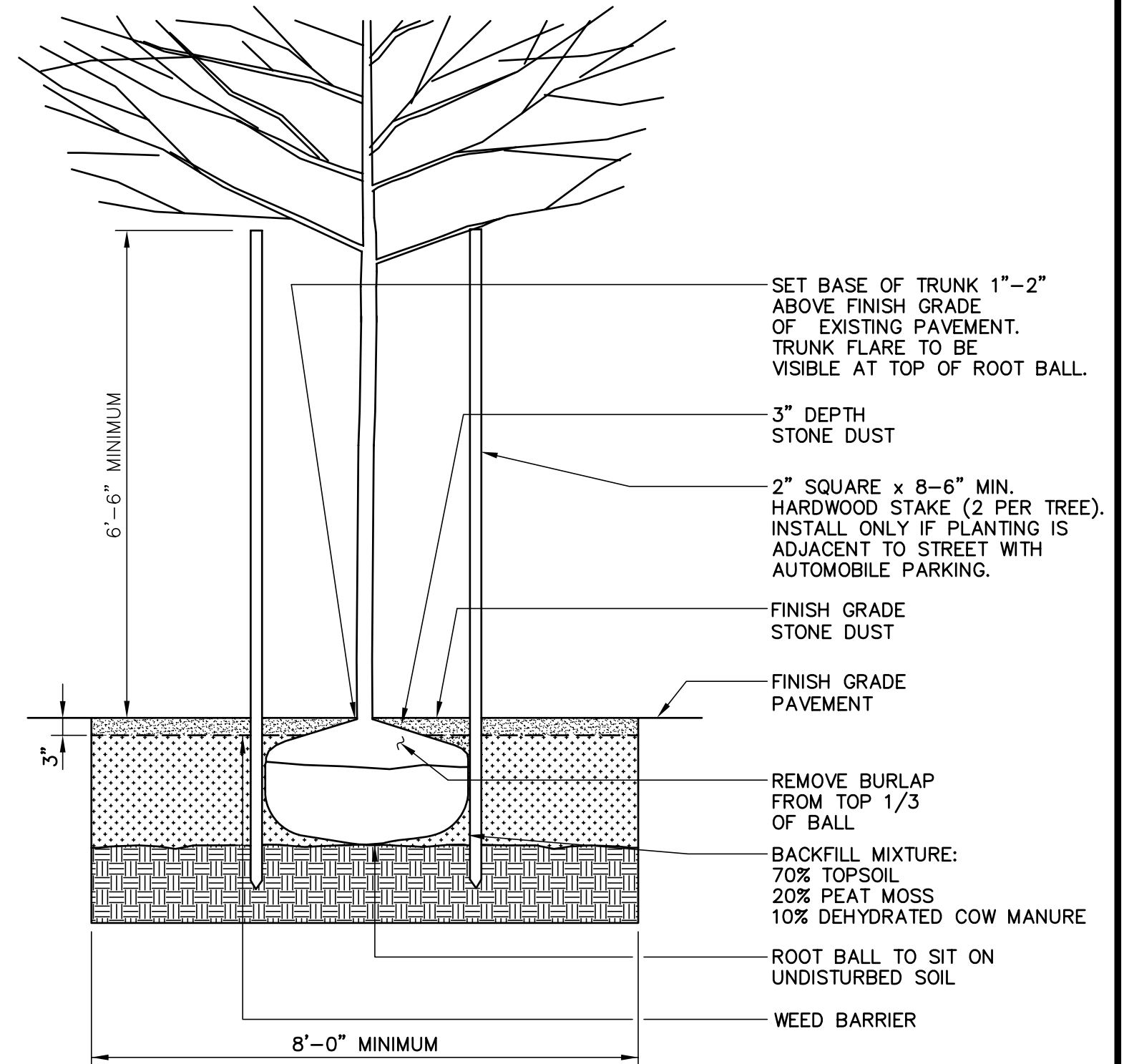

TREE PIT WITH STONE DUST SURFACE

SCALE: 1/2"=1'-0"

NOTES:

1. 4' x 4' OPENING IS MINIMUM SIZE OPENING FOR TREE PIT. IF SITE CONDITIONS AND DESIGN PERMITS, LARGER TREE PIT DIMENSIONS ARE ACCEPTABLE AND DESIRED. IF SITE CONDITIONS DO NOT PERMIT A 4' x 4' SIZE TREE PIT AND/OR REQUIRE A TREE PIT SIZE OF A DIFFERENT DIMENSION, THEN THE PROPOSED TREE PIT SIZE SHALL BE SUBMITTED TO THE LANDSCAPE ARCHITECT'S OFFICE FOR APPROVAL.
2. NO TREE PIT SHALL BE LOCATED CLOSER THAN 25' FROM A STOP SIGN AND/OR 25' FROM THE INTERSECTION OF THE BACK SIDES OF TWO SIDEWALKS (SIDE OF SIDEWALK FARTHEST AWAY FROM STREET).
3. THE PLACEMENT OF A TREE PIT SHALL IN NO CASES RESULT IN THE SIDEWALK WIDTH BEING LESS THAN 5' WIDE.
4. MARK NORTH SIDE OF THE TREE IN NURSERY AND LOCATE TO TO THE NORTH IN FIELD.

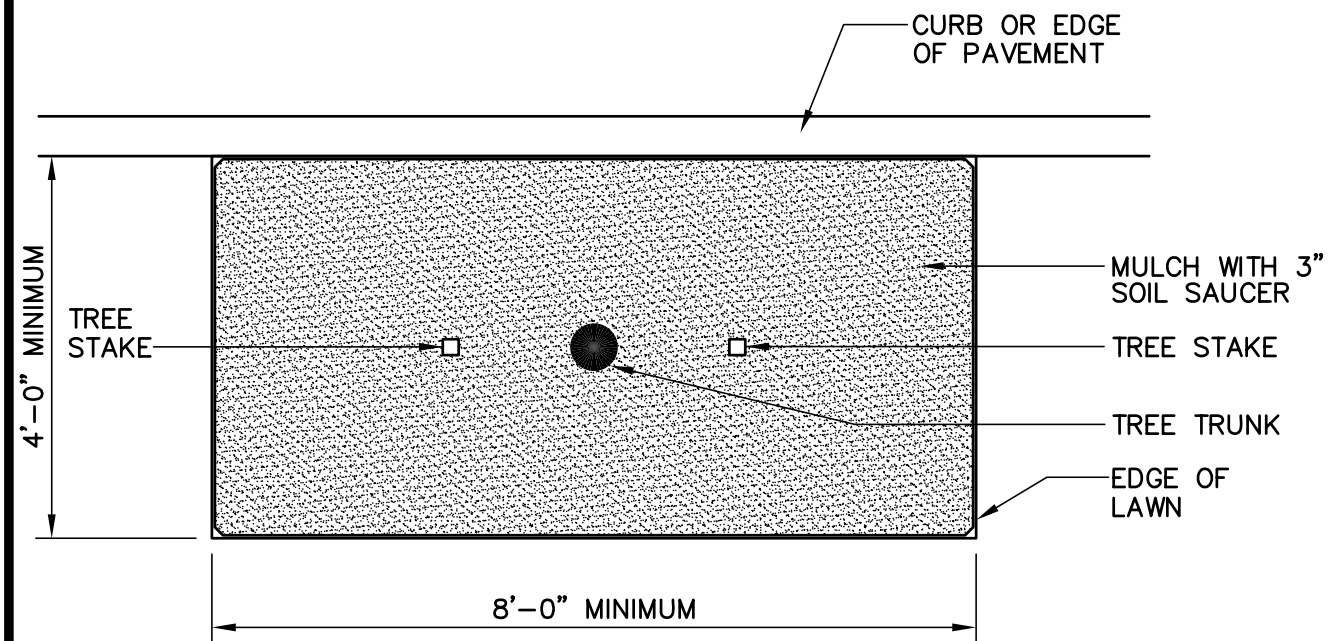

PLAN VIEW

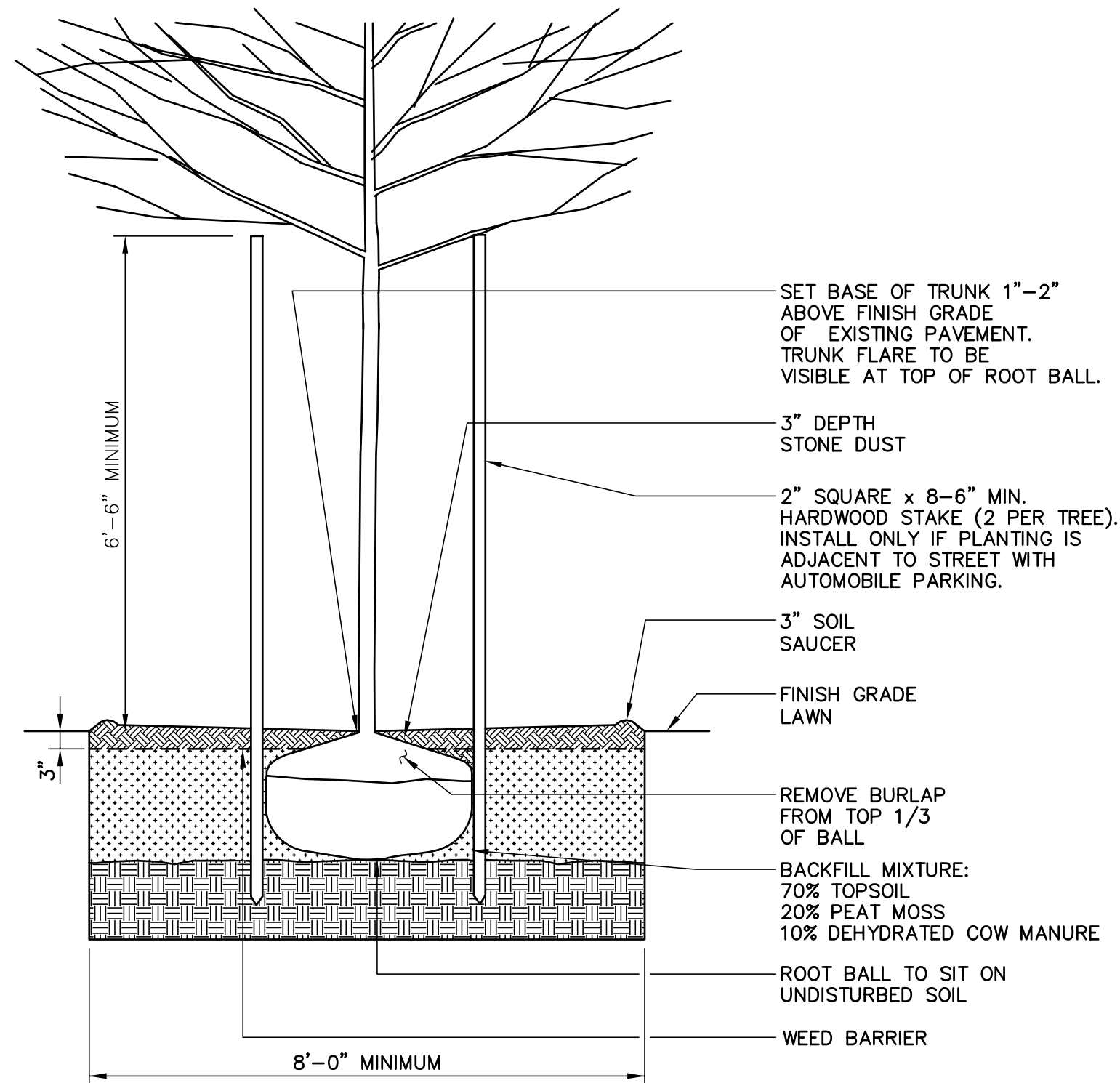

TREE PLANTING WITH MULCH SAUCER

SCALE: 1"=1'-0"

CITY OF NEW HAVEN
DEPARTMENT OF ENGINEERING

RICHARD H. MILLER, P.E., L.S. 9886
CITY ENGINEER

DRIVE:
K:\ENGINEER\DWG
FILE:
CITYSTD\DETAILS\2009 DETAILS
DATE:
DEC. 1, 2009
DRAWING NO.:
STD-NH-32B

TREE PROTECTION NOTES:

1. BEFORE BEGINNING ANY SITE REMOVALS OR CONSTRUCTION, TREE PROTECTION FENCING SHALL BE INSTALLED AS SHOWN AND DETAILED ON THE DRAWINGS AND/OR AS DIRECTED IN THE FIELD BY THE ENGINEER. FOLLOWING THE INSTALLATION OF TREE PROTECTION FENCING AND FOR THE ENTIRE CONSTRUCTION PERIOD THE FOLLOWING SHALL APPLY:
 - NO MATERIALS, VEHICLES OR EQUIPMENT MAY BE STORED OR STOCKPILED WITHIN THE AREAS ENCLOSED BY TREE PROTECTION FENCING.
 - NO VEHICLES OR EQUIPMENT MAY BE DRIVEN, OPERATED OR PARKED WITHIN AREAS ENCLOSED BY TREE PROTECTION.
 - AREAS ENCLOSED BY TREE PROTECTION CAN NOT BE USED AS ROUTES FOR SITE TRAFFIC
 - FENCING SHALL BE RESECURED AS NECESSARY AND MAINTAINED TAUT. FENCING SHALL BE REPAIRED OR REPLACED WHEN DAMAGED AT NO ADDITIONAL COST.
 - IN SPECIAL CASES WHERE CONSTRUCTION OPERATIONS ABSOLUTELY REQUIRE SOME TEMPORARY ENCROACHMENT INTO TREE PROTECTION AREAS, THE CONTRACTOR SHALL PRESENT A WORK PLAN FOR TEMPORARY ENCROACHMENT FOR THE ENGINEER'S APPROVAL.
2. ALL EXCAVATION OR TRENCHING WITHIN THE AREAS OF EXISTING TREE ROOTS SHALL BE CARRIED OUT BY HAND.
 - ROOTS IN TRENCH SHALL BE CUT SMOOTH AND CLEAN USING SHARP TOOLS. NO RIPPING OF TREE ROOTS BY MACHINES IS PERMITTED.
 - NO JAGGED EDGES OF ROOTS SHALL BE PERMITTED.
 - SIDES OF EXCAVATIONS SHALL BE CLEAN AND STRAIGHT.
 - IMMEDIATELY FOLLOWING TRENCHING OR EXCAVATION OPERATIONS, AREAS AT TREE ROOTS SHALL BE BACKFILLED.
 - ROOTS SHALL NOT BE LEFT EXPOSED OVERNIGHT.
 - BACKFILL SHALL BE A MIX OF 50% TOPSOIL AND 50% CLEAN SAND.
 - BACKFILL SHALL BE HAND COMPACTED IN PLACE TO FILL ALL VOIDS.
3. EXTREME CARE SHALL BE TAKEN TO AVOID ANY DAMAGE TO TRUNKS, BRANCHES AND ROOTS. ANY DAMAGE CAUSED TO TREES SHALL BE IMMEDIATELY REMEDIATED BY THE CONTRACTOR.
 - REMEDIAL WORK MAY INCLUDE PRUNING, WOUND TREATMENT, CABLING OR ADDITIONAL MEASURES AS DETERMINED BY THE ENGINEER.
 - CONTRACTOR SHALL ENGAGE A LICENSED ARBORIST TO PERFORM ALL WORK AT NO ADDITIONAL COST TO THE OWNER.
4. THE CONTRACTOR SHALL REVIEW ALL PLANNED CONSTRUCTION OPERATIONS THAT MAY RESULT IN TREE DAMAGE FOR REVIEW AND APPROVAL BY THE ENGINEER.
 - SPECIAL ATTENTION SHALL BE MADE TO THE PATH OF PLACING CONSTRUCTION MATERIAL ON SITE BY CRANE.
 - THE CONTRACTOR SHALL PRESENT A WORK PLAN AND PROPOSED TREE PROTECTION MEASURES TO MINIMIZE DAMAGE TO TREES.

TREE PROTECTION NOTES

SCALE: NONE

**CITY OF NEW HAVEN
DEPARTMENT OF ENGINEERING**

RICHARD H. MILLER, P.E., L.S. 9886
CITY ENGINEER

DRIVE: K:\ENGINEER\DWG
FILE: CITYSTD\DETAILS\2009 DETAILS
DATE: DEC. 1, 2009
DRAWING NO.:
STD-NH-32C

TREES SUITIBLE FOR PLANTING IN THE TREE BELT

SPECIES	VARITIES PERMITTED	VARITIES PROHIBITED
ACER RUBRUM (RED MAPLE)	OCTOBER GLORY RED SUNSET COLUMNAR VARIETIES COLUMNAR VARIETIES	SILVER MAPLE NORWAY MAPLE
ACER SACCHARUM (SUGAR MAPLE)	GREEN MOUNTAIN	
CARPINUS BETULUS/ FASTIGIATA' 'COLUMNARIS (EUROPEAN HORNBEAM)	FASTIGATE	
PYRUS CALLERYANA (CALLERY PEAR)	CHANTICLEER ARISTOCRAT REDSPIRE	BRADFORD
TILIA CORDATA (LITTLELEAF LINDEN)	GREENSPIRE SALEM	
ZELKOVA SERRATA (JAPANESE ZELKOVA)	VILLAGE GREEN GREEN VASE	
GLEDITSIA TRIACANTHOS INERMIS (THORNLESS HONEY LOCUST)	SUNBURST SHADEMASTER MAJESTIC SKYLINE	ANY VARIETY THAT HAS SEED PODS OR THORNS. LONDON PLANETREE SYCAMORE
ROBINA PSEUDOACACIA (BLACK LOCUST)	PYRAMIDALIS BESSONIANA	ANY VARIETY THAT HAS SEED PODS OR THORNS.
FRAXINUS PENNSYLVANICA (GREEN ASH)	MARSHALL'S SEEDLESS NEWPORT PATMORE	
QUERCUS PALUSTRIS (PIN OAK)		

TREES SUITIBLE FOR PLANTING UNDER UTILITY WIRES

SPECIES	VARITIES PERMITTED	VARITIES PROHIBITED
ACER BUERGERANUM (TRIDENT MAPLE)		
ACER CAMPESTRE (HEDGE MAPLE)		
PRUNUS SERRULATA 'KWANZAN' (KWANZANN CHERRY)		
PRUNUS SARGENTII (COLUMNAR SARGENT CHERRY)	COLUMNARIS ACCOLADE	
SYRINGA RETICULATA (JAPANESE TREE LILAC)	IVORY SILK REGENT SUMMER SNOW	

RECOMMENDED TREE TYPES

SCALE: NONE

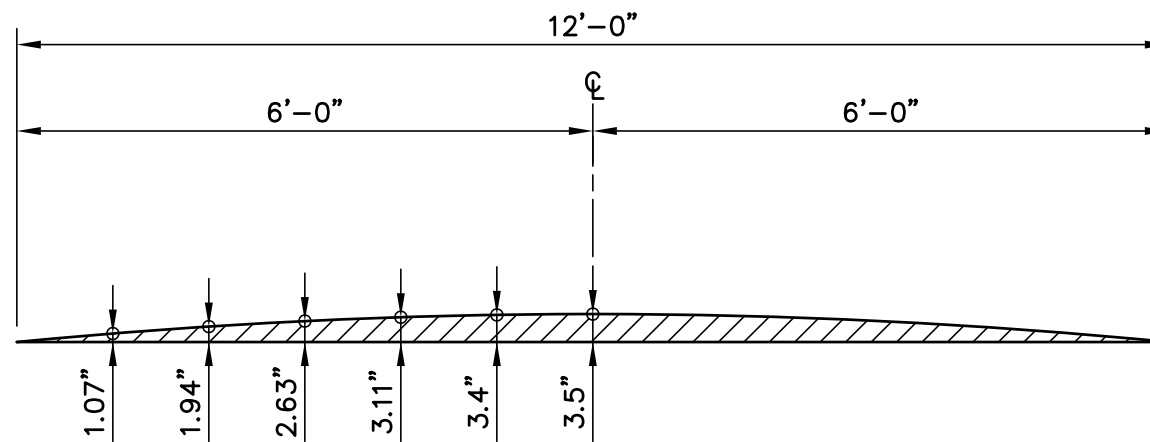

CROSS SECTION
NOT TO SCALE

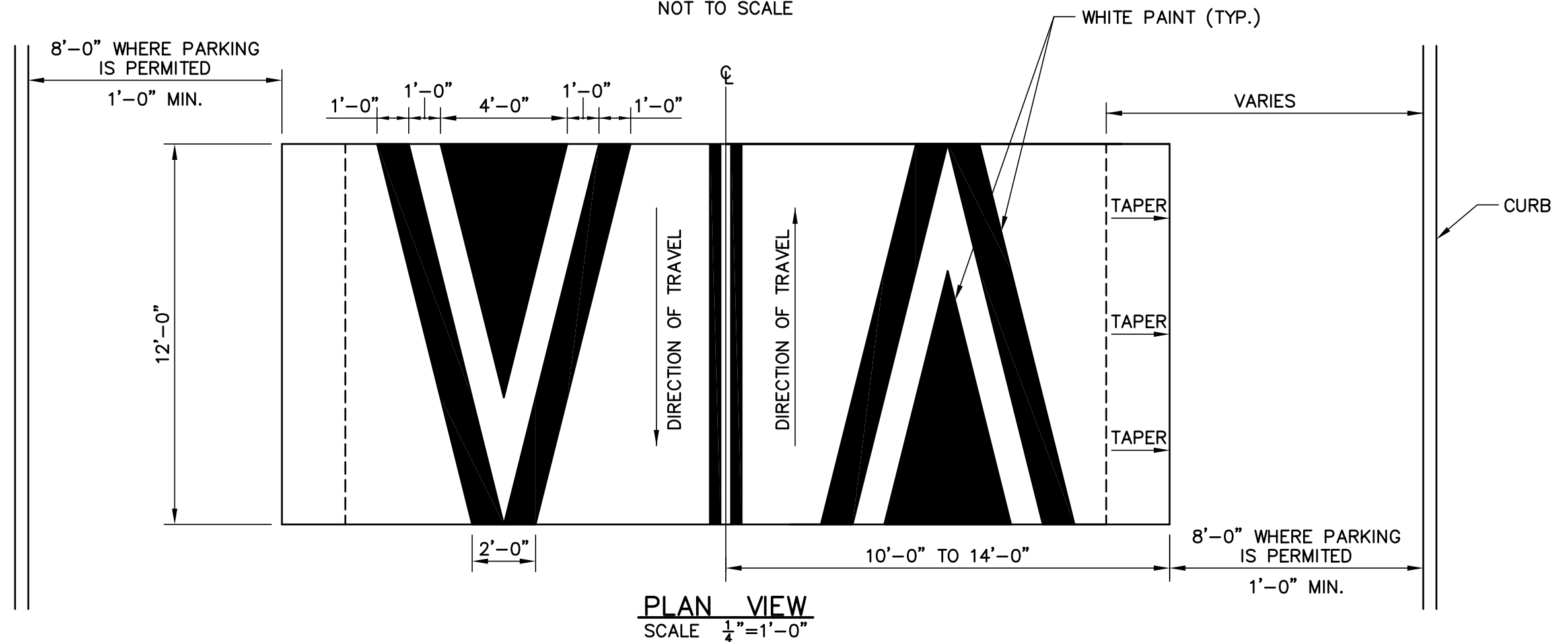

PLAN VIEW
SCALE 1/4" = 1'-0"

SPEED HUMP DETAIL

SCALE: AS NOTED

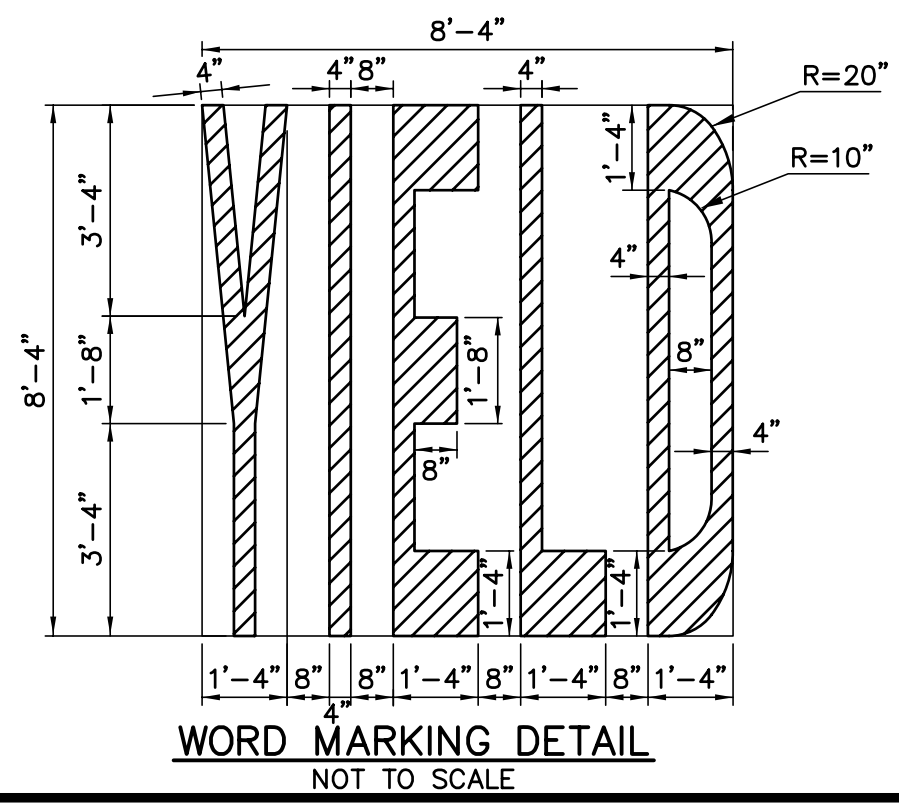
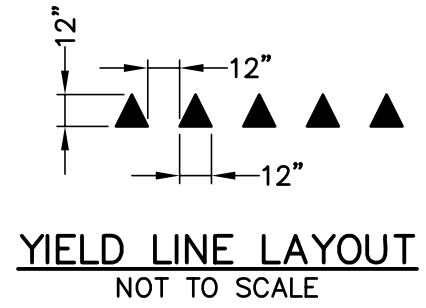
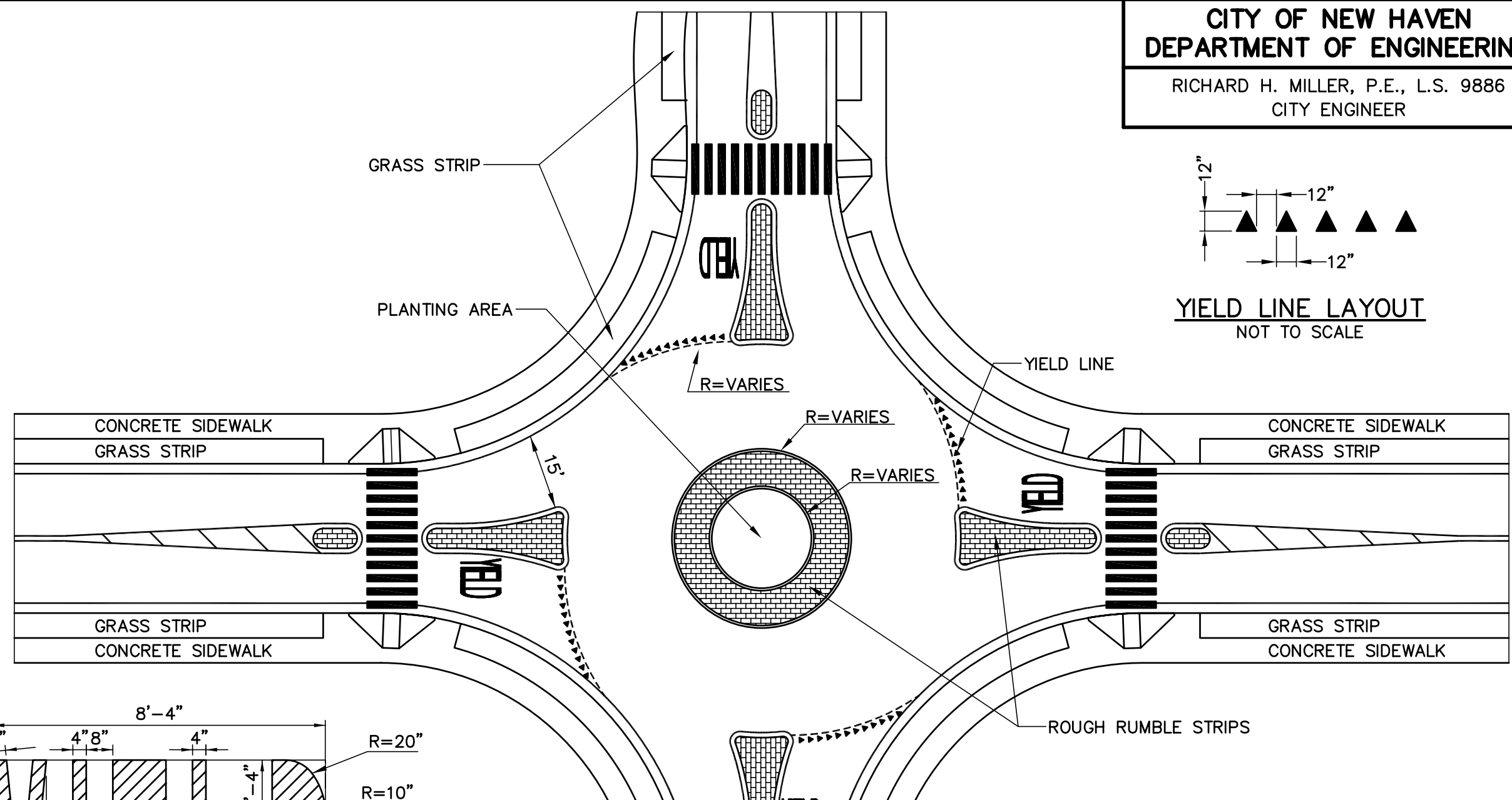

**TYPICAL ROUND ABOUT DETAIL
FOR INTERSECTIONS**

SCALE: 1/2" = 1'-0"

- NOTES:**
1. ROUND ABOUT SIZE MAY VARY.
 2. ANY CROSSWALK MUST BE LOCATED AWAY FROM INTERSECTION AS SHOWN.
 3. SIGNAGE SHALL BE PER MUTCD.
 4. CONSTRAINTS OF SITE MAY VARY RADIUS AND SIZES.
 5. SURFACE TREATMENT MAY VARY.
 6. TYPICAL ASSUMES R.O.W. IS AVAILABLE FOR ALL MOVEMENTS ENCOUNTERED.

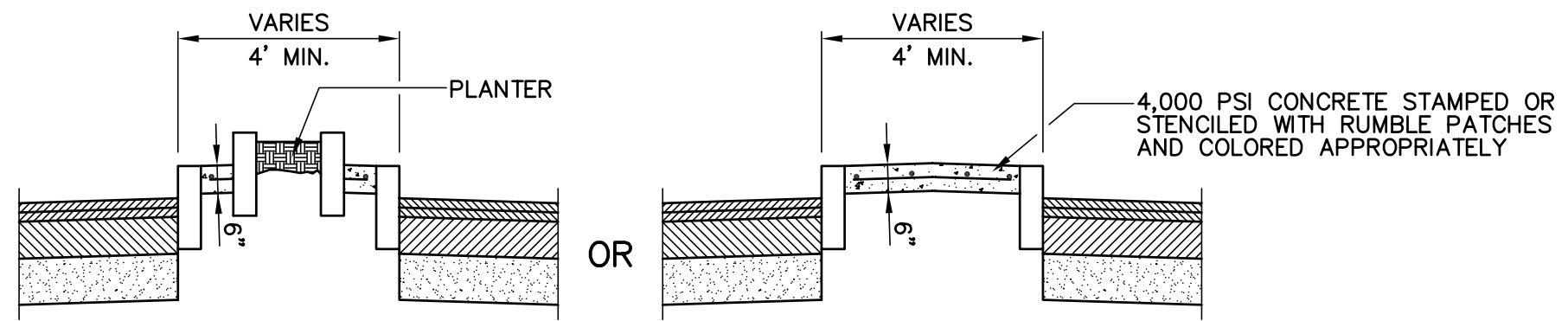

CENTER MEDIAN
NOT TO SCALE

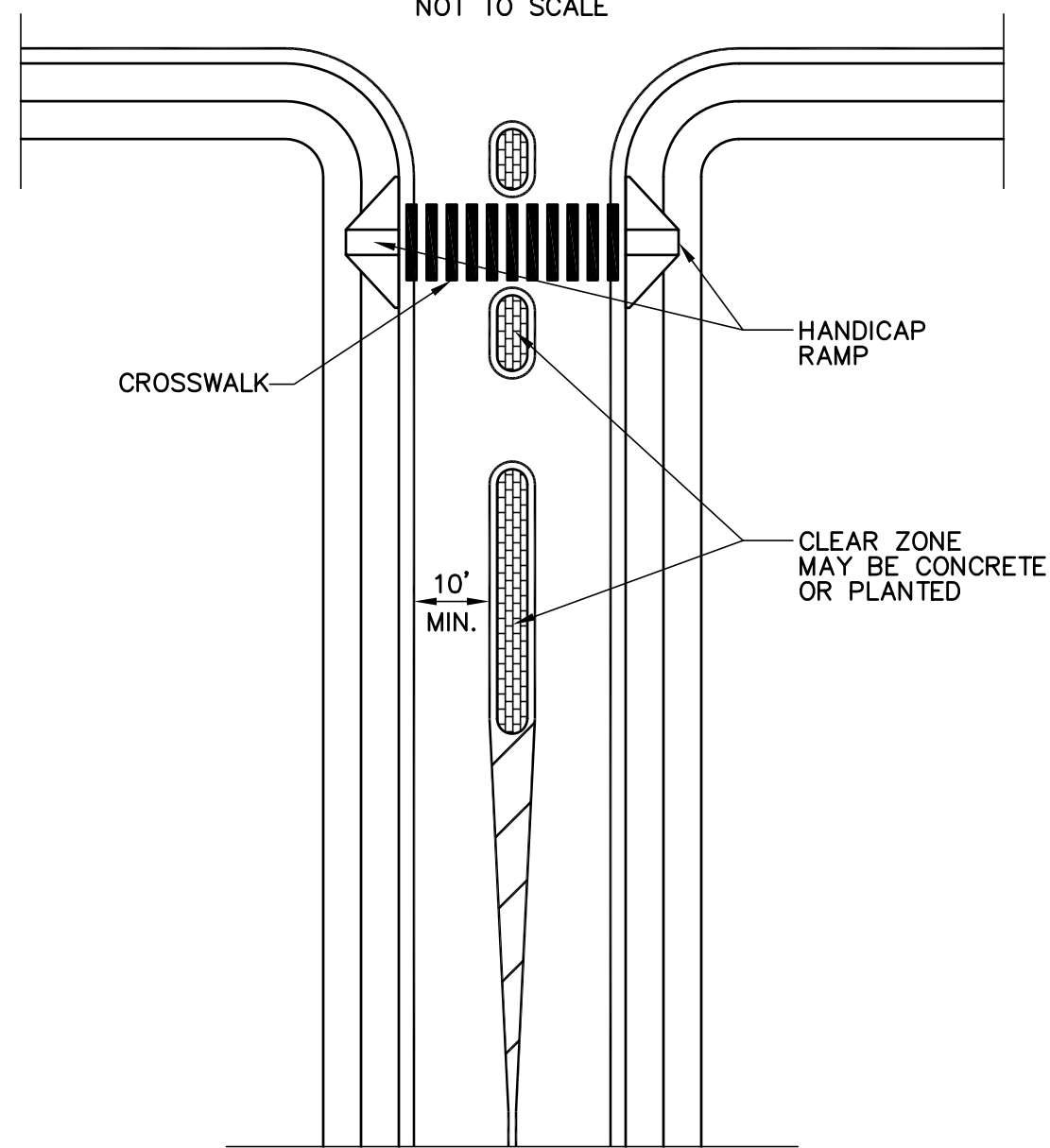

**CROSSING ISLANDS/
CENTER MEDIANS**

NOTES:
1. WIDTH OF ROAD MUST PROVIDE ADEQUATE LANES FOR THE ROADS DEFINED USE.

SCALE: 1/2"=1'-0"

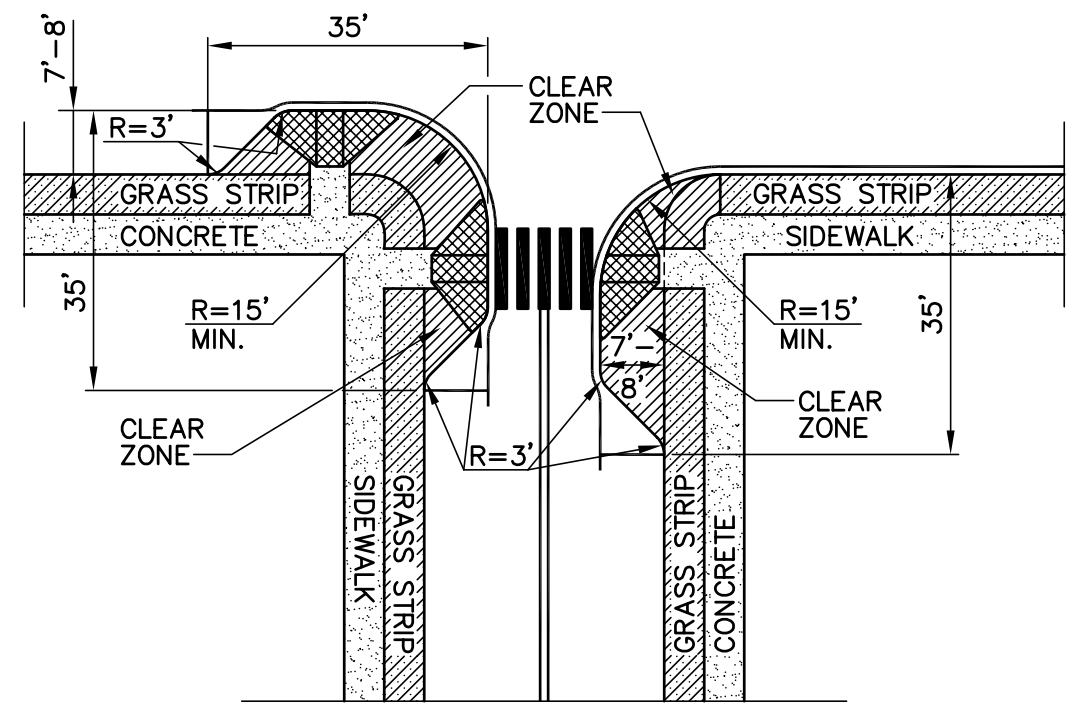

**TYPICAL BUMP OUT DETAIL
FOR INTERSECTIONS**

SCALE: 1/2"=1'-0"

NOTES:
1. CONFIGURATION MAY VARY BASED ON DRAINAGE REQUIREMENT.
2. CLEAR ZONES MAY BE USED FOR PLANTING AS APPROPRIATE TO MAINTAIN LINE OF SIGHT.

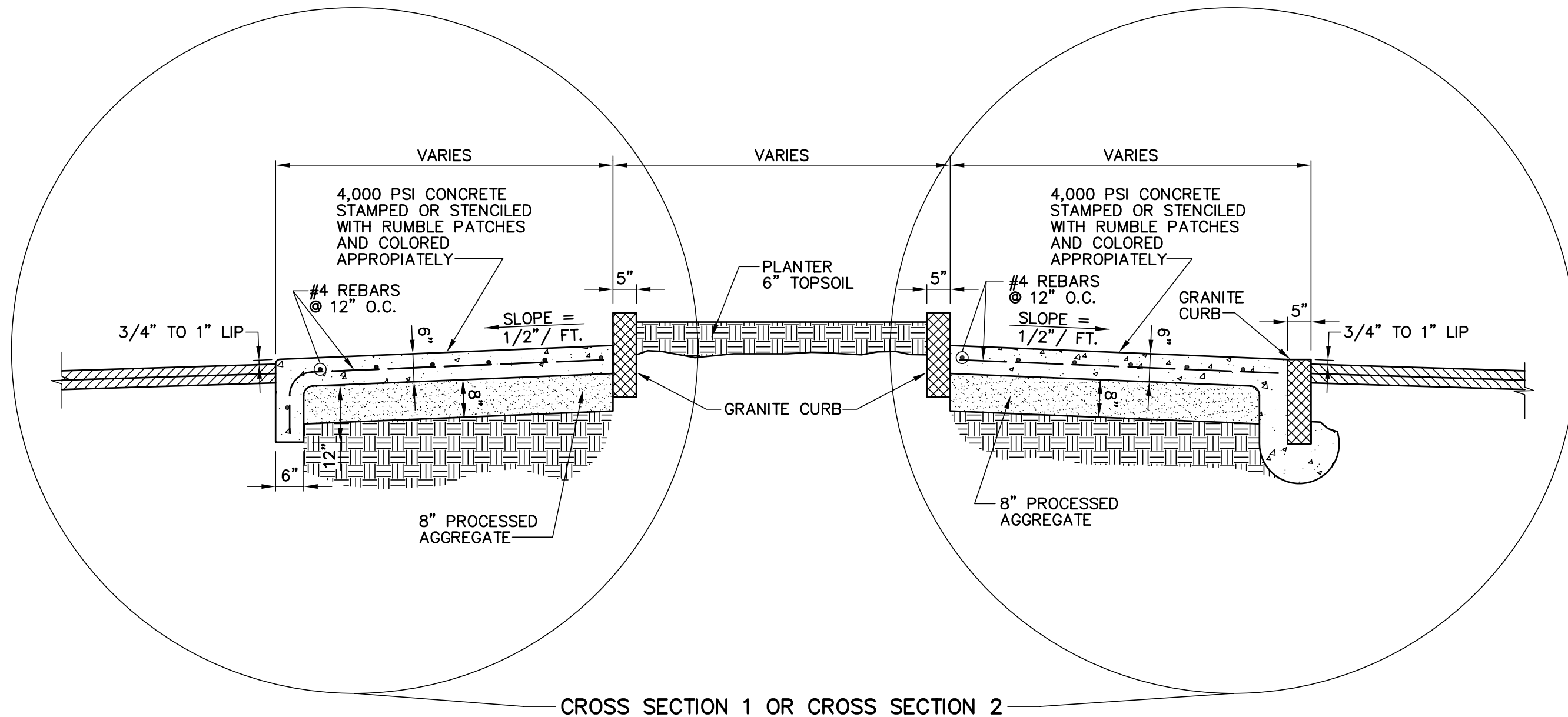

CENTER ROUND ABOUT

TYPICAL CROSS SECTION

SCALE: 1/2" = 1'-0"

APPENDIX E: DECISION MATRIX

Design criteria for the street design tools described above are included in the following Decision Matrix. These criteria will ensure that a selected technique not only is appropriate for a given road and project, but also have the traffic characteristics that will ensure a successful installation.

ROAD ACTIVITY		Calming			Streets					Sidewalks					INVOLVEMENT GUIDELINES							CLASSIFICATION GUIDELINES							
		No Road Work Planned	0	3	6	7	15	20	20	36	Resurfacing	Mill and Pave	Road Reconstruction	New Road	Sidewalk Repair	Sidewalk Reconstruction	New Sidewalk	Neighborhood Interest	Community Support	Adjacent Neighbor Consent	Education	City Interest	Speed/Volume Study	Engineering Justification	Principal Arterial >10,000 vpd	Minor Arterial 5,000-10,000 vpd	Collector 1,000-5,000 vpd	Local 500-1,000 vpd	Low-Volume Local <500 vpd
Service Life (years)		0	3	6	7	15	20	20	36																				
Lead Time (months)		0	3	6	7	15	20	20	36																				
Enhancement																													
Pedestrian																													
Sidewalk widening		Y	Y	Y	Y	Y	Y	Y	Y	Y	Y	Y	Y	Y	Y	Y	Y	Y	Y	Y	Y	Y	Y	Y	Y	Y	Y	Y	Y
Handicapped ramps		Y	Y	Y	Y	Y	Y	Y	Y	Y	Y	Y	Y	Y	Y	Y	Y	Y	Y	Y	Y	Y	Y	Y	Y	Y	Y	Y	Y
Street furniture		Y	Y	Y	Y	Y	Y	Y	Y	Y	Y	Y	Y	Y	Y	Y	Y	Y	Y	Y	Y	Y	Y	Y	Y	Y	Y	Y	Y
Crosswalks																													
Surface treatment		Y	Y	Y	Y	Y	Y	Y	Y	Y	Y	Y	Y	Y	Y	Y	Y	Y	Y	Y	Y	Y	Y	Y	Y	Y	Y	Y	Y
Tree belt enhancements		Y	Y	Y	Y	Y	Y	Y	Y	Y	Y	Y	Y	Y	Y	Y	Y	Y	Y	Y	Y	Y	Y	Y	Y	Y	Y	Y	Y
Mobility		N	Y	Y	Y	Y	Y	Y	Y	Y	Y	Y	Y	Y	Y	Y	Y	Y	Y	Y	Y	Y	Y	Y	Y	Y	Y	Y	Y
Pavement Markings		Y	Y	Y	Y	Y	Y	Y	Y	Y	Y	Y	Y	Y	Y	Y	Y	Y	Y	Y	Y	Y	Y	Y	Y	Y	Y	Y	Y
Surface treatment		Y	Y	Y	Y	Y	Y	Y	Y	Y	Y	Y	Y	Y	Y	Y	Y	Y	Y	Y	Y	Y	Y	Y	Y	Y	Y	Y	Y
Speed Humps		Y	Y	Y	Y	Y	Y	Y	Y	Y	Y	Y	Y	Y	Y	Y	Y	Y	Y	Y	Y	Y	Y	Y	Y	Y	Y	Y	Y
Islands		Y	Y	Y	Y	Y	Y	Y	Y	Y	Y	Y	Y	Y	Y	Y	Y	Y	Y	Y	Y	Y	Y	Y	Y	Y	Y	Y	Y
Chokers / Bump-outs		Y	Y	Y	Y	Y	Y	Y	Y	Y	Y	Y	Y	Y	Y	Y	Y	Y	Y	Y	Y	Y	Y	Y	Y	Y	Y	Y	Y
Circles		Y	Y	Y	Y	Y	Y	Y	Y	Y	Y	Y	Y	Y	Y	Y	Y	Y	Y	Y	Y	Y	Y	Y	Y	Y	Y	Y	Y
Chicanes		Y	Y	Y	Y	Y	Y	Y	Y	Y	Y	Y	Y	Y	Y	Y	Y	Y	Y	Y	Y	Y	Y	Y	Y	Y	Y	Y	Y
Diversers		Y	Y	Y	Y	Y	Y	Y	Y	Y	Y	Y	Y	Y	Y	Y	Y	Y	Y	Y	Y	Y	Y	Y	Y	Y	Y	Y	Y
Road Closures		Y	Y	Y	Y	Y	Y	Y	Y	Y	Y	Y	Y	Y	Y	Y	Y	Y	Y	Y	Y	Y	Y	Y	Y	Y	Y	Y	Y
Traffic Patterns		Y	Y	Y	Y	Y	Y	Y	Y	Y	Y	Y	Y	Y	Y	Y	Y	Y	Y	Y	Y	Y	Y	Y	Y	Y	Y	Y	Y
Roundabouts		Y	Y	Y	Y	Y	Y	Y	Y	Y	Y	Y	Y	Y	Y	Y	Y	Y	Y	Y	Y	Y	Y	Y	Y	Y	Y	Y	Y
Roadway narrowing		N	Y	Y	Y	Y	Y	Y	Y	Y	Y	Y	Y	Y	Y	Y	Y	Y	Y	Y	Y	Y	Y	Y	Y	Y	Y	Y	Y
Bicycle		Y	Y	Y	Y	Y	Y	Y	Y	Y	Y	Y	Y	Y	Y	Y	Y	Y	Y	Y	Y	Y	Y	Y	Y	Y	Y	Y	Y
Bike lanes		Y	Y	Y	Y	Y	Y	Y	Y	Y	Y	Y	Y	Y	Y	Y	Y	Y	Y	Y	Y	Y	Y	Y	Y	Y	Y	Y	Y
Sharrows		Y	Y	Y	Y	Y	Y	Y	Y	Y	Y	Y	Y	Y	Y	Y	Y	Y	Y	Y	Y	Y	Y	Y	Y	Y	Y	Y	Y
Signage		Y	Y	Y	Y	Y	Y	Y	Y	Y	Y	Y	Y	Y	Y	Y	Y	Y	Y	Y	Y	Y	Y	Y	Y	Y	Y	Y	Y

APPENDIX F: BICYCLE BOULEVARDS

A bicycle boulevard is a shared roadway where the bicycle, or any other human-powered vehicle, is the primary design vehicle. Compared to traditional bicycle lanes or shared lane markings, the bicycle boulevard is a relatively new concept. Accordingly, its definition and application is much less standardized than other types of bicycle infrastructure improvements. Different cities and towns have competing definitions and design guidelines. However, all bicycle boulevards should have several key characteristics. These are:

- Low motor vehicle speeds, typically less than 20 miles per hour;
- Traffic control devices that have been optimized for the through movement of bicycles and other human-powered vehicles;
- Distinctive signage and pavement markings to signify to motorists that bicycles have the right to use of the full roadway, including the right to occupy the center of the travel lane;
- Distinctive wayfinding signage for bicycles is also an important feature of many bicycle boulevards.

In order to achieve the objectives outlined above it may be necessary to reconfigure STOP signs so as to encourage the movement of bicycles along the boulevard and minimize delays for those roadway users. It may also be necessary to install traffic calming devices to achieve the abovementioned target speed of 20 miles per hour.

Bicycle boulevards should be considered as a potential improvement on residential streets or neighborhood streets where high-volume, high-speed motor vehicle traffic is undesirable. The design features of the street should discourage or prevent motor vehicle through traffic (see Figure 1 below). When there are relatively low motor vehicle volumes on a bicycle boulevard or when a bicycle boulevard runs parallel to major roadway better suited to carrying high volume, high speed traffic, motorists should be prohibited from overtaking cyclists, with the exception of emergency vehicles. This

latter prohibition relieves much of the psychological stress that cyclists often experience when riding in front of a motorist who may be eager to overtake them. This stress can discourage new or inexperienced bicyclists and relieving this stress can increase the number of cyclists in an area.

Figure 1. (Partial motor vehicle diverter: Bicycle-only entrance, all vehicles may exit.)



Over time, many new cyclists will come to gain experience riding on bicycle boulevards with motor vehicles and will develop the skills necessary to ride on a wider variety of roads, leading to an overall increase in bicycle use for transportation. Cities that have implemented bicycle boulevards include: Portland, Ore., Berkeley, Calif. and Vancouver, British Columbia. In some of the neighborhoods where bicycle boulevards have been constructed, 10-20% of trips are now made by bicycle. A video illustrating the use of bicycle boulevards in Berkeley, Calif., can be found at: <http://www.streetfilms.org/archives/berkeley-bike-boulevards/>. Finally, bicycle boulevards often have higher surfacing/pavement quality standards than other roadways due to the fact that bicycles and other human powered vehicles are more sensitive to roadway defects such as potholes and longitudinal cracks.

APPENDIX G: BICYCLE PARKING

Bicycle Parking and Storage

Just as the amount of available parking can encourage or reduce of motor vehicle travel, an ample supply of bicycle parking can increase the number of cyclists on the road. In New Haven, as in cities throughout the country, bicycle theft remains a significant problem and therefore a major deterrent to bicycle transportation. In many ways, the available parking supply represents the terminal capacity of the bicycle transportation system. Simply put, people will be reluctant or unwilling to utilize the bicycle as a form of transportation if they are not certain that they will have a safe place to secure their bicycle at the end of each trip. A failure to accommodate cyclists parking needs may result in a modal shift away from bicycling and a corresponding increase in automobile travel and the associated costs that accompany it, including increased pollution, traffic congestion and demand for automobile parking facilities.

As a result, it is essential that City of New Haven be committed to providing high-quality bicycle parking in sufficient quantity to meet current and projected demands. Broadly speaking, bicycle parking can be broken into four (4) categories. These are:

- Short Term Public Parking;
- Long-Term Public Parking;
- Short Term Private Parking;
- Long-Term Private Parking.

Short-Term Public Bicycle Parking

Typical “inverted u” bicycle rack in New Haven



Short-term public parking is the most commonly utilized and, therefore, the most important type of bicycle parking. It is typically provided in the form of bicycle racks and is used for short trips such as errands or outings to restaurants and shopping areas. Most often, this type of parking is provided within the public Right-of-Way along the sidewalk. While there are many types of bicycle racks, the “inverted-U” design is widely recognized as the best type of rack for short-term bicycle parking and is recommended by the Association of Bicycle and Pedestrian Professionals (APBP). APBP publishes a guide to bicycle parking, which can be found in the appendix. It is recommended that this guide be adopted by the City of New Haven and be used when planning for and installing short-term public bicycle parking.

Installation of short term public bicycle parking should occur wherever possible when demand warrants it. This includes downtown New Haven, neighborhood retail clusters, schools and municipal buildings. Parking should be installed both in anticipation of demand as well as upon requests from residents and community and business groups.

In areas with high levels of sustained bicycle parking demand, the City will consider accommodating bicycle parking demand through on-street bicycle parking, or “bicycle corrals”. Bicycle corrals are comprised of a series of bicycle racks installed in areas that would typically be utilized for on-street parking for automobiles are typically protected by some combination of curbing, striping and bollards. In addition to providing large amounts of bicycle parking without obstructing pedestrians and others on the sidewalk, bicycle corrals can often accommodate up to twelve bicycles in an area that would have accommodated a single automobile.



Bicycle Corral – Columbia, MO
Source: www.seeclixfix.com

Long-Term Public Parking



Long-term public bicycle parking is necessary when cyclists have to store their bicycles away from their homes for an extended period of time. Demand of this type of bicycle parking is most common at major transit hubs where cyclists may be arriving by bicycle and then switching to other modes of transportation such as trains or buses. It is also necessary outside of major public sector employers such as schools, libraries, municipal buildings. Long-term bicycle parking should be located inside buildings whenever possible to protect bicycles from theft as well as inclement weather. Depending on building type and location, indoor bicycle parking may be effectively provided in a number of ways, including:

- Bicycle racks inside New Haven Parking Authority (NHPA) garages;
- Covered parking at major transit hubs;
- Bicycle racks in the basement of public buildings;
- Bicycle storage areas inside of public schools;
- Bicycle stations offering staffed parking areas such as the City Hall Bicycle Station.

Private Bicycle Parking

Private bicycle parking includes residential parking, bicycle parking provided by business, and bicycle parking provided by institutions. As part of its efforts to develop a transportation system that serves all users effectively, the City will encourage and, at times, require private business and institutions to provide safe and accessible bicycle parking. Just as the City often requires private developers and organizations to provide a specified amount of automobile parking through minimum parking requirements, similar consideration should be given to bicycle parking during the site plan approval process. As with publicly provided parking, private organizations should provide both short-term and long-term bicycle parking facilities.

APPENDIX H: TREE POLICIES

New Haven is famously known as “Elm City” in the post-civil war era due to the planting of numerous elm trees by James Hillhouse and David Austin and for the preservation of older trees already standing since the year 1790, which serve as “shade and ornament to the City.” Compared to a treeless landscape, downtown shoppers linger longer, traffic slows, crime is reduced, and property values soar where healthy trees shade urban streets. Trees and natural views have been also been found to be effective in soil erosion control, stormwater management and in the treatment of various developmental disorders. Hence, tree planting should be incorporated as a component and feature of any site development and/or work within the public right-of-way.

A tree belt is recommended between the curb and the project property line whenever possible. The width of the tree belt should be as wide as possible. A minimum width of 5’ is desired unless site conditions do not make this width feasible. Lawn is the preferred surface within the tree belt to maximize the soil volume and to promote tree growth and vitality. If lawn is not feasible as a surface within the tree belt, then adequate openings within paved areas should be provided for placement of soil to support tree growth. The preferred minimum opening for a tree pit is 4’ by 8’. To maximize the number of trees incorporated within a tree belt, the minimum recommended distance between tree plantings is 25’. Depending on the tree species and site conditions, trees should be spaced 25’ to 40’ at the center. No tree should be planted closer than 25’ to a street corner. Any tree that is to be planted underneath an overhead utility wire should have a maximum mature height of 30’.

Proper care should be taken to avoid conflicts between tree planting and utility lines located within the public right-of-way. Tree roots may sometimes damage these utility lines and cause considerable expense and discomfort to property owners and public service authorities involved. In order to protect and minimize disturbance to the existing street trees located in areas of proposed construction, the tree protection policies outlined in the following **Section 7025** are recommended.

During construction of sidewalks, the “Zone of Rapid Taper” should be clearly determined and marked so that it is clearly visible during all phases of construction. If construction work requires the cutting of roots in the “Zone of Rapid Taper”, a tree preservation plan should be required (see form). If the construction work takes place outside of the “Zone of Rapid Taper but may/will impact roots of the tree, the tree should be watered beginning one week before the start of the construction, through out the construction period, and for one week after the completion of construction. Thus, watering should occur at a minimum of every four days during this period. If practical, the “Zone of Rapid Taper” should be fenced during all phases of construction. Clean soil should be placed between the pruned roots and construction area. For example, a form may be placed against a cut root and when this form is removed soil is replaced. A contractor may want to and/or be required to enhance these measures by the City Arborist or Tree Warden. For non-city contractors performing any pruning, removal, or disturbance to the City’s street trees located on City property, City right-of-ways, or the tree belt of City streets, the policies outlined in the following **Section 7025** are applicable.

In case of new tree plantings along public rights-of-way, the policies outlined in Section 02930 are recommended to be followed (Section 02930 Planting can be provided upon request). Private property owners should be educated about the role of street trees in traffic calming and encouraged to plant and maintain trees on the front yards of their properties. Public-private partnerships need to be fostered as a first step. A list of recommended and discouraged street trees can be provided by the City of New Haven as well as the City’s policy on using non-city contractors.

SECTION 7025 TREE PROTECTION

7025.10 DESCRIPTION

Work under this item shall include the furnishing and installation of tree protection and root removal during any construction activity within the City Right of Way or as directed by the Engineer in accordance with these specifications. It is the City's policy that healthy trees within the city right of way are appropriately protected during any construction activity that affects the canopy or root zone of the tree(s). Activities of excavation such as sidewalk construction or utility trenching must consider the health and protection of the tree(s) for any disturbance of the root zone or canopy. The following section shall apply.

7025.20 QUALITY ASSURANCE

Prior to any construction activity within the City Right of Way where trees may be affected by the work being proposed, the contractor shall contact the Urban Forester, at the New Haven Department of Parks, Recreation and Trees at 203-946-6556. At his/her direction the potential tree(s) that are affected shall be inventoried and a determination made as to its health and anticipated protection required to ensure the construction activities will have a minimal impact on the identified tree(s). If required the contractor may be directed to hire an independent licensed arborist as approved by the Department of Parks, Recreation and Trees to guide the contractor on protective measures or work that is necessary to minimize damage to the tree(s) impacted.

7025.21 MATERIALS AND EQUIPMENT

During construction where pruning is involved the equipment being used must follow OSHA and ANSI standards including bucket trucks, chippers, and personnel safety equipment. When working around tree roots the contractor shall not use any equipment that rips or tears at the root zone. Hand tools and appropriate excavation methods of care around root zones are required. Back fill material, if required, in formed tree wells shall be clean soil.

7025.30 CONSTRUCTION METHODS

Excavations or sidewalk removals and replacements require careful recognition of the tree(s) that may be affected by the construction activity. Removal of sidewalks where tree roots have raised the walk require special attention after the initial screening by the Urban Forester. Any sidewalk that has tree root intrusion should be carefully removed by peeling off the slab or broken-up with hand tools and removed. Where applicable, the

contractor shall provide the largest tree well possible creating a root zone for the tree and a minimum sidewalk area for passage at 48". In extreme cases 42" may be required. Any tree roots over 6" in diameter that interfere with the safe minimum passage shall be pruned by a licensed arborist with a minimum of five years experience as approved by the Department of Parks, Recreation and Trees. The following provides further guidance:

A. Protection of Existing Trees

1. All trees shall be protected from damage to trunks, branches and roots.
2. Do not disturb the existing grade inside the tree root zone unless otherwise indicated or directed in the field by the Engineer. The root zone is considered equal to the branch spread of the tree.
3. No materials, vehicles or equipment shall be stored, or stockpiled within the root zone of existing trees.
4. Machinery shall not be driven over the root zone unless it is absolutely necessary to gain access to the construction site.
5. The contractor shall exercise caution in operating all machinery so that there is no damage to tree trunk, roots or branches.

B. Root Pruning

1. All excavation required within the area of existing tree roots shall be carried out by hand.
2. Roots shall be cut smooth and clean using sharp root cutting tools in accordance with good arboricultural practice. Cutting, ripping or tearing of tree roots using a backhoe or other non hand tool is not permitted.
3. Pruning of tree roots shall be kept to the absolute minimum necessary to install sidewalk and base course.
4. Root removal and materials covering existing roots shall be timed so exposed roots are not left exposed overnight or over non-working days or weekends.
5. All roots that will be left exposed for more than three hours shall be sprayed periodically with water and/or covered with moisture laden material to keep the roots moist.
6. Pruning of any root 6" or greater in diameter shall be done by a licensed/certified arborist or an urban forester employed by the New Haven Department of Parks, Recreation & Trees. To contact an urban forester employed by the New Haven Department of Parks, Recreation & Trees call 410-2482. Urban foresters require 24 hours notice before coming to the job site.

C. Tree Repair

1. Any damage caused to trees by the work of this contract through negligence by the contractor shall be immediately remedied by the contractor.
2. Remedial work may include pruning, wound treatment, cabling, or additional support measures as determined by the Engineer.
3. Contractor shall engage a licensed arborist to perform such work, as approved by the Engineer.
4. All required remedial work shall be performed to the satisfaction of the New Haven Department of Parks, Recreation and Trees, at no additional cost to the Owner.

D. Tree Replacement

1. If damage to any tree is severe, because of negligence by the contractor as determined by the New Haven Department of Parks, Recreation and Trees, it shall be replaced with a new tree of equal size caliper and species as that of the damaged tree.
2. If a replacement tree of equal size caliper is not possible, it shall be a minimum caliper size of 4".
3. Replacement trees shall be supplied and installed at no additional costs to the Owner, including all incidental costs including the costs of inspection of the tree at the nursery and any other incidental costs associated with tree replacement.

7025.40 METHOD OF MEASUREMENT

Unless specifically identified as a pay item per tree, all work as required under these specifications shall be made part of the work being performed that affects any tree(s) within the city right of way or as directed.

7025.50 BASIS OF PAYMENT

Payment for this work shall be included as part of other bid items of the contract, unless identified as a pay item per tree.