

This drawing is property of Spring City Elect. Mfg. and is issued to the recipient with the understanding that it shall not be copied, duplicated, passed on to unauthorized parties, nor used for any purpose other than that for which it is specifically furnished except with Spring City's written permission.

NOTE TO CONTRACTORS AND VENDORS:

CONDUIT AND WIRE SIZE MAY VARY DEPENDING ON PROJECT. IT IS UP TO THE CONTRACTORS OR VENDORS TO SUBMIT SHOP DRAWINGS TO THE CITY ENGINEERING DEPARTMENT FOR APPROVAL TO INSURE CONFORMANCE WITH THESE SPECIFICATIONS.

**CITY OF NEW HAVEN
DEPARTMENT OF ENGINEERING**

RICHARD H. MILLER, P.E., L.S. 9886
CITY ENGINEER

DRIVE: C:\ENGINEER\DWG\CITYSTD
FILE: DETAILS\LIGHTING STANDARDS\2011 DETAILS
DATE: JULY 1, 2011
DRAWING NO.: LD-NH-32

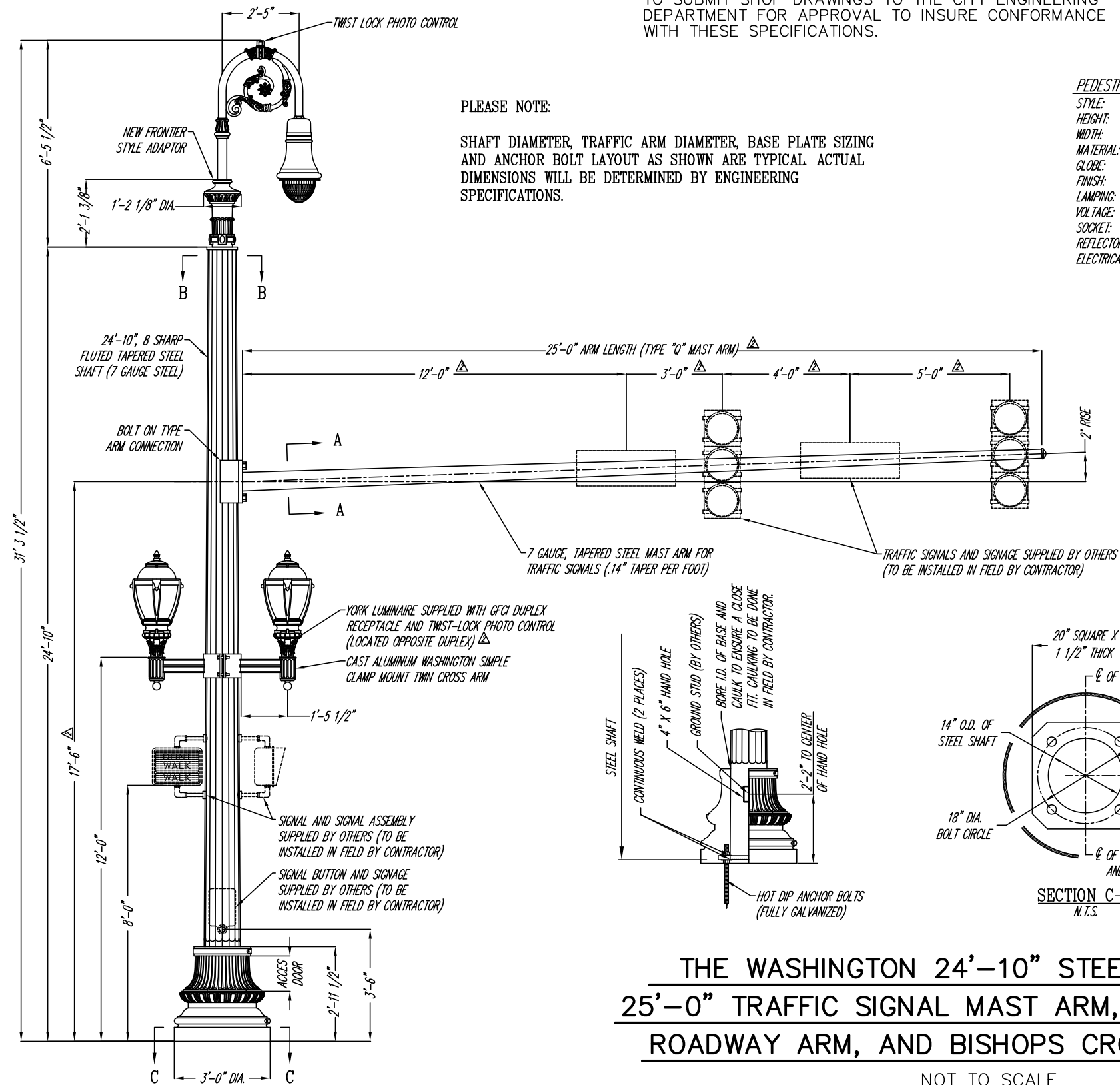

PLEASE NOTE:

SHAFT DIAMETER, TRAFFIC ARM DIAMETER, BASE PLATE SIZING AND ANCHOR BOLT LAYOUT AS SHOWN ARE TYPICAL ACTUAL DIMENSIONS WILL BE DETERMINED BY ENGINEERING SPECIFICATIONS.

PEDESTRIAN LUMINAIRE SPECIFICATIONS

STYLE: YORK
HEIGHT: 39 1/2"
WIDTH: 20"
MATERIAL: SPUN ALUMINUM AND CAST ALUMINUM
GLOBE: UV STABILIZED RIPPLED ACRYLIC
FINISH: FINISH PAINTED BLACK
LAMPING: 150 WATT METAL HALIDE (LAMP BY OTHERS)
VOLTAGE: 120 VOLT
SOCKET: MOGUL BASE
REFLECTOR: SEGMENTED ALUMINUM REFLECTOR
ELECTRICAL: GFCI DUPLEX RECEPTACLE
TWIST-LOCK PHOTO CONTROL

ROADWAY LUMINAIRE SPECIFICATIONS

STYLE: BISHOPS CROOK
HEIGHT: 33"
WIDTH: 17" DIAMETER
MATERIAL: SPUN ALUMINUM AND CAST ALUMINUM
GLOBE: REFRACTIVE POLYCARBONATE
FINISH: 250 WATT METAL HALIDE (LAMP BY OTHERS)
LAMPING: 120 VOLT
VOLTAGE: 120 VOLT
SOCKET: MOGUL BASE

CROOK SPECIFICATIONS

STYLE: BISHOP'S CROOK WITH NEW FRONTIER ADAPTOR
HEIGHT: 6'-5 1/2"
WIDTH: 2'-5" FROM L OF POST TO L OF LUMINAIRE
MATERIAL: STEEL PIPE WITH CAST ALUMINUM ORNAMENTATION
FINISH: PRIME PAINT THEN FINISH PAINT, SHERWIN WILLIAMS ACRYLON - CLASSIC BLACK
TENON: 2" NPT PIPE NIPPLE

CLAMP MOUNT ARM SPECIFICATIONS

STYLE: WASHINGTON SIMPLE (CLAMP MOUNT TWIN)
HEIGHT: 12 1/4"
WIDTH: 1'-5 1/2" FROM CLAMP TO L OF LUMINAIRE
MATERIAL: CAST ALUMINUM
FINISH: PRIME PAINT THEN FINISH PAINT, SHERWIN WILLIAMS ACRYLON - CLASSIC BLACK
TENON: 3" DIA. X 3 1/2" HIGH

SIGNAL POST SPECIFICATIONS

STYLE: WASHINGTON STEEL WITH SINGLE MAST ARM
HEIGHT: 24'-10"
BASE: 36" DIAMETER
MATERIAL: STEEL SHAFT: 7 GAUGE, 16 SHARP FLUTE STEEL MONOTUBE CONSTRUCTION
TRAFFIC ARM: SMOOTH TAPERED STEEL MONOTUBE CONSTRUCTION
BASE: TWO PIECE, (WRAP AROUND) CAST DUCTILE IRON PER A.S.T.M. A536-84, GRADE 65-45-12
FINISH: PRIME PAINT THEN FINISH PAINT, SHERWIN WILLIAMS ACRYLON - CLASSIC BLACK
ACCESS DOOR: LOCATED IN BASE SECURED WITH TAMPER PROOF HEX SOCKET SECURITY MACHINE SCREWS
GROUND PROVISIONS: 1/4"-20 SQUARE NUT FOR GROUND STUD WELDED TO INSIDE OF STEEL SHAFT OPPOSITE ACCESS DOOR TO COINCIDE WITH HAND HOLE (GROUND STUD BY OTHERS)
ANCHOR BOLTS: (4) 1" DIA. X 30" + 4" HOOK (FULLY GALVANIZED WITH 2 GALVANIZED WASHERS AND 2 GALVANIZED NUTS PER BOLT)
BOLT PROJECTION: 5" REQUIRED

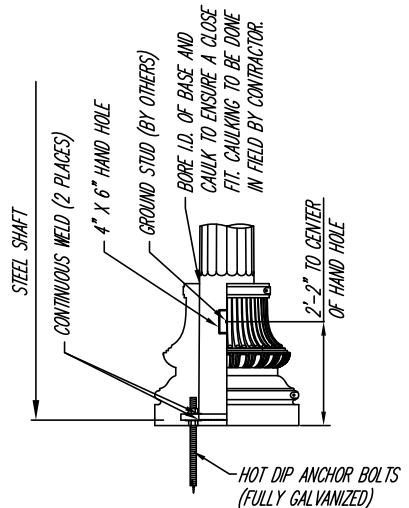
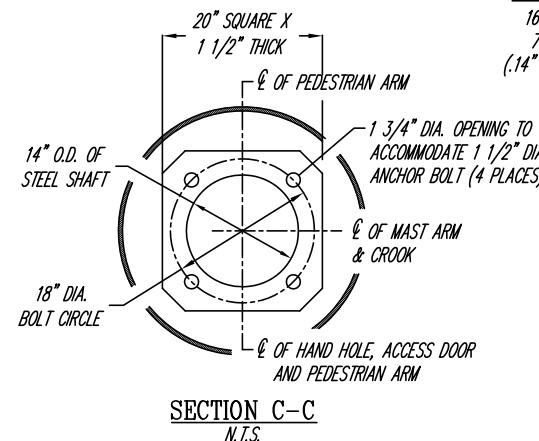
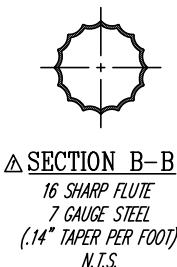
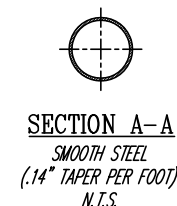

**THE WASHINGTON 24'-10" STEEL POST WITH
25'-0" TRAFFIC SIGNAL MAST ARM, BISHOPS CROOK
ROADWAY ARM, AND BISHOPS CROOK LUMINAIRE**

NOT TO SCALE

STEEL POSTS AND SIGNAL MAST ARM

AS NOTED

REVISOR: B.K.R.	DATE: 04-08-11
REVISOR: B.K.R.	DATE: 03-21-11
 Spring City Electrical Mfg. Co. HALL AND MAIN STREETS - P.O. BOX 19 - SPRING CITY, PA. 19475 PHONE (610) 948-4000 - FAX (610) 948-5577 - WWW.SPRINGCITY.COM	
DESCRIPTION	THE WASHINGTON 24'-10" STEEL POST WITH 25'-0" TRAFFIC SIGNAL MAST ARM, BISHOP'S CROOK ROADWAY ARM AND BISHOP'S CROOK LUMINAIRE
CUSTOMER	NEW HAVEN, CT
SCALE	N.T.S.
DRAWN BY:	B.K.R.
DATE	03-10-11
SPEC. NO.	S102007B