

FLUID COLLISIONS

NOT TO SCALE

CITY OF NEW HAVEN
DEPARTMENT OF ENGINEERING

RICHARD H. MILLER, P.E., L.S. 9886
CITY ENGINEER

DRIVE: K:\ENGINEER\DWG
FILE: CITYSTD\DETAILS\2009 DETAILS
DATE: DEC. 1, 2009
DRAWING NO.: **STD-NH-34B**

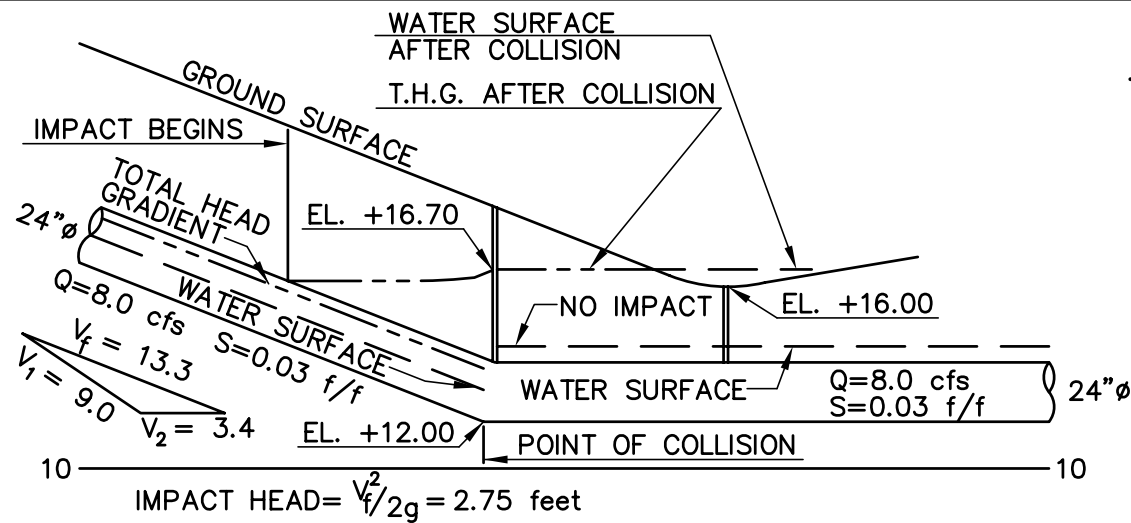

**CASE NO. 1 -
IMPACT IN UPSTREAM PIPE**

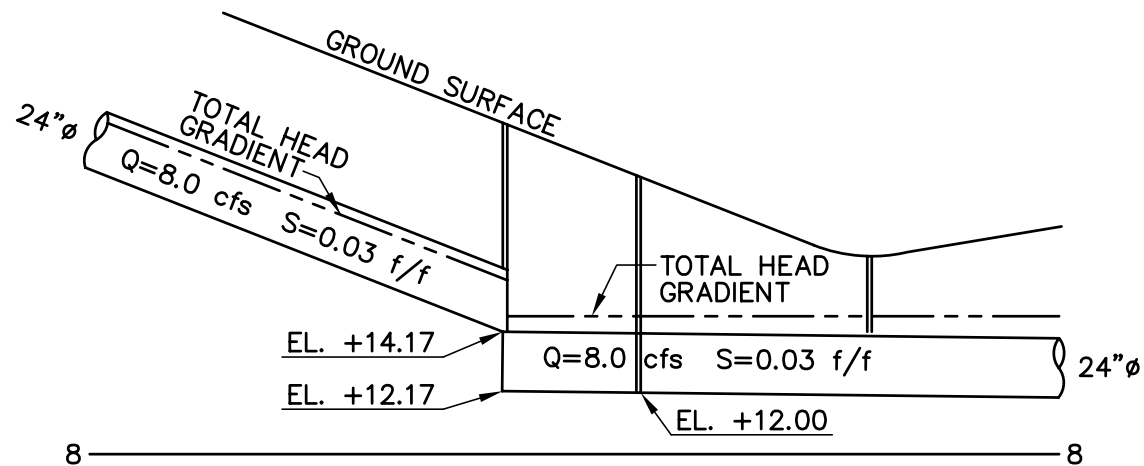

**CASE NO. 2 -
DROP MANHOLE, NO IMPACT**

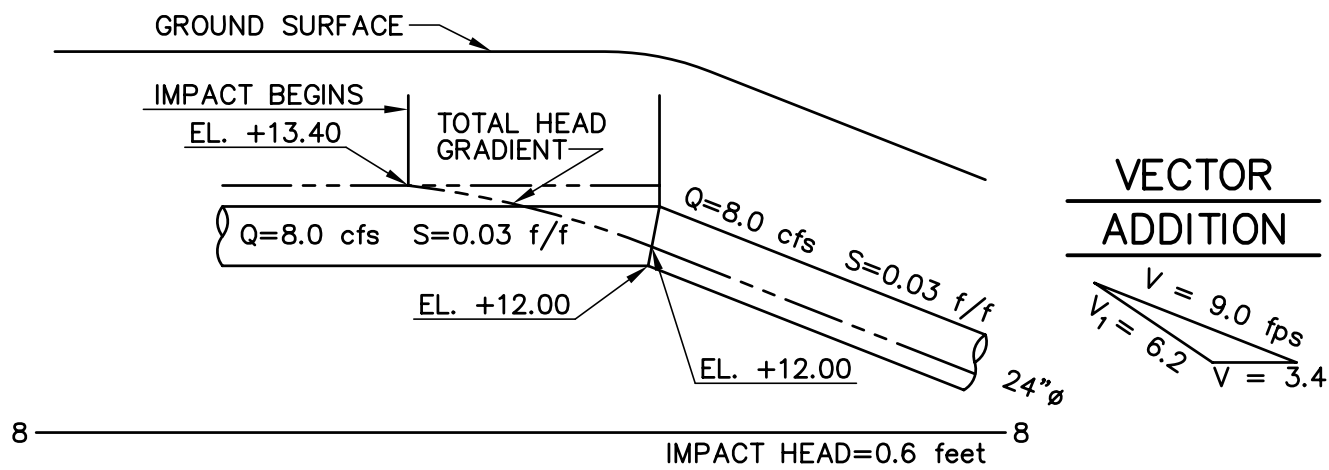

**CASE NO. 3 -
IMPACT IN DOWNSTREAM PIPE**

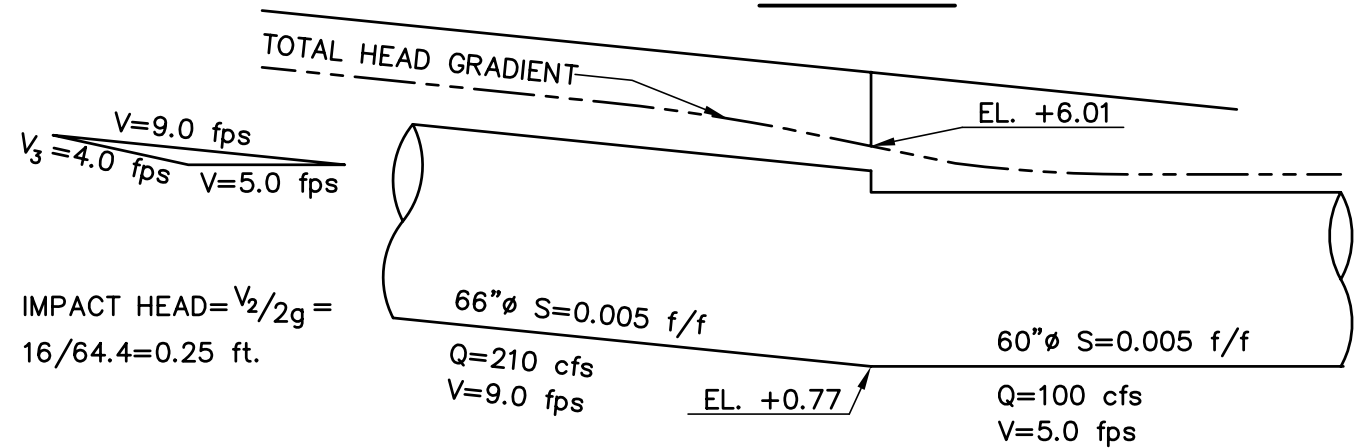
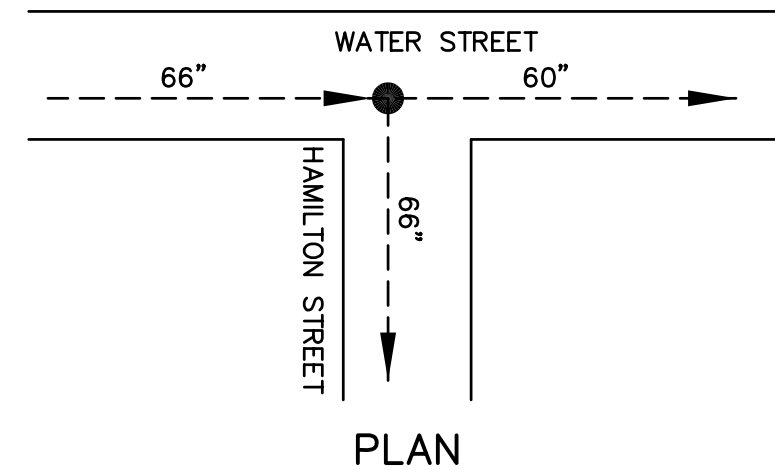

WATER STREET OUTLET

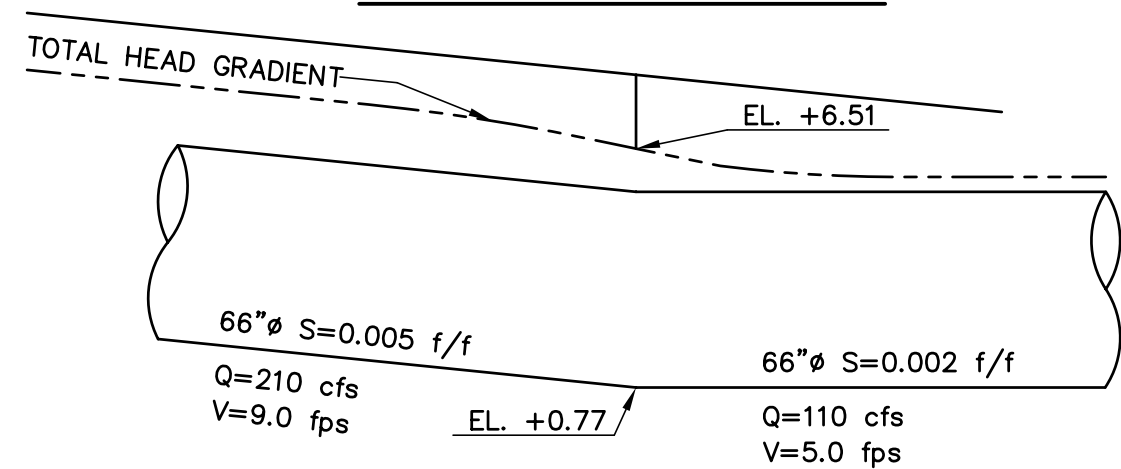

HAMILTON STREET OUTLET

CASE NO. 4 - SPLIT FLOW