

**ROUND PIPE TERMINAL,
CORNER OR PULL POST**

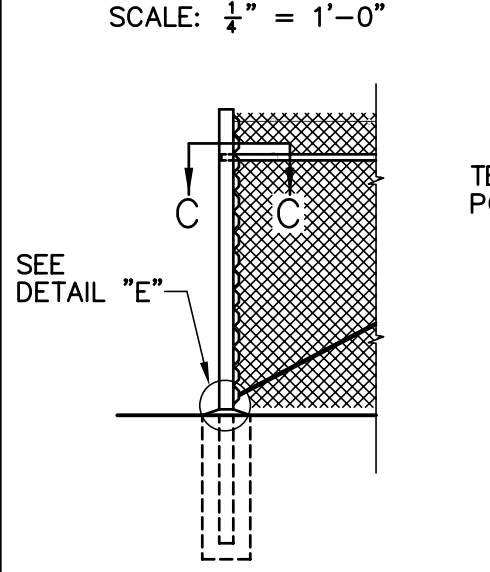

**ROLL-FORMED SECTION
TERMINAL, CORNER OR
PULL POST**

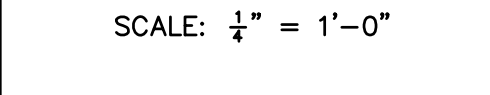

**DETAIL "E"
TRUSS ROD
ATTACHMENT**

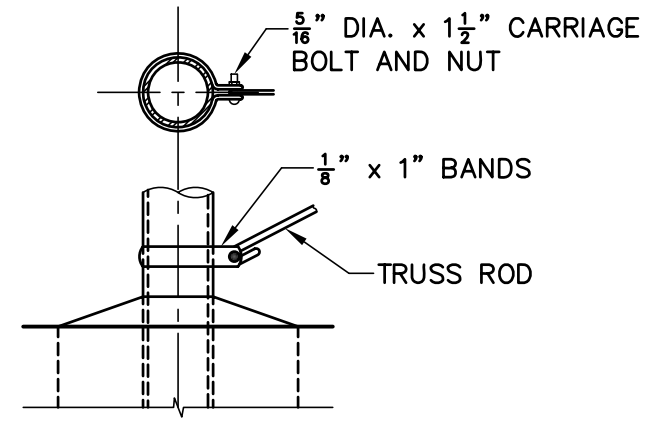
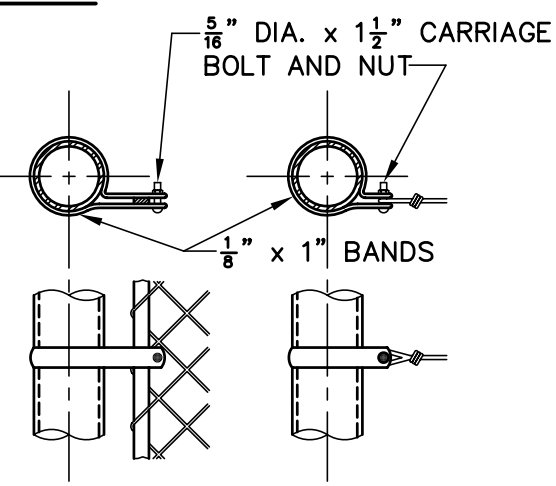
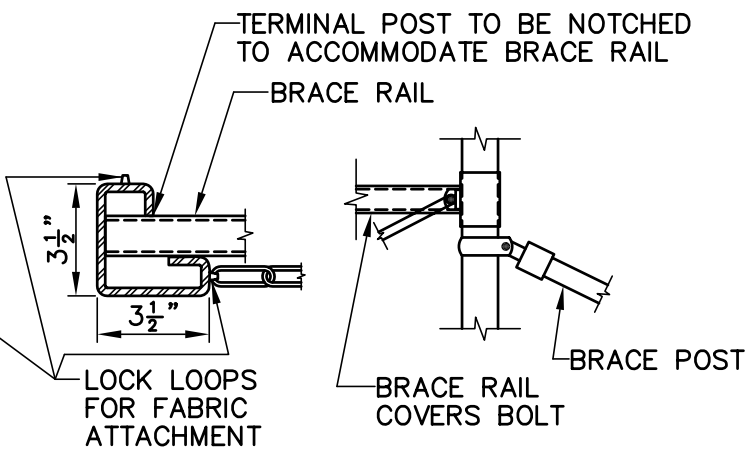
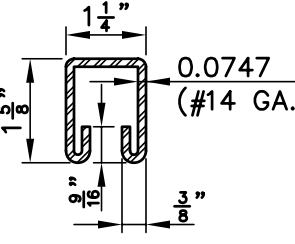
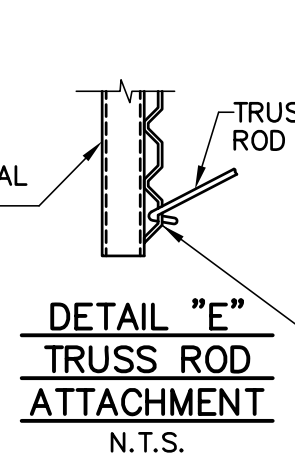

**ROLLED - FORMED SECTION DETAILS
TYPICAL CHAIN LINK FENCE DETAILS**

AS SHOWN

NOTE:
SEE SHEET STD-NH-31A FOR FURTHER DETAILS.