

**TYPICAL MILLING DETAIL
FOR LOCAL ROADS**

NO SCALE

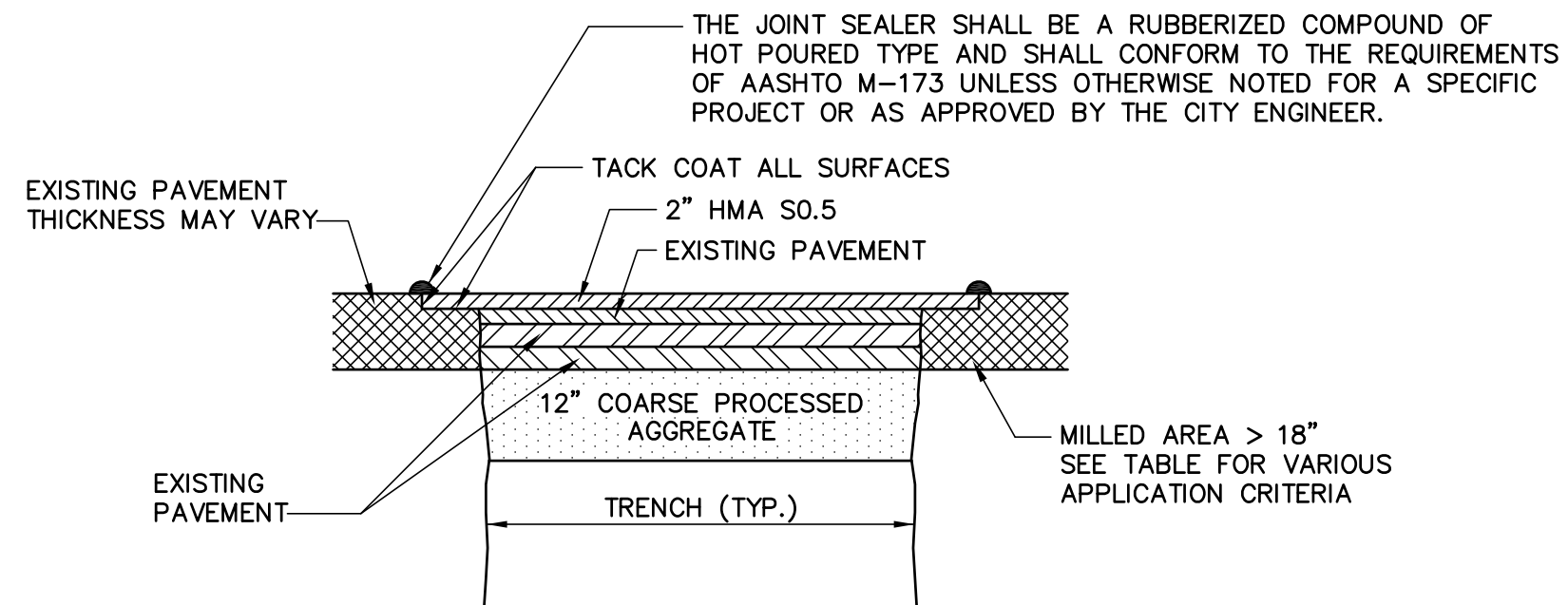

**TYPICAL MILLING DETAIL
FOR COLLECTOR ROADS**

NO SCALE

NOTE:
UNLESS OTHERWISE NOTED, ALL MATERIALS AND CONSTRUCTION METHODS USED SHALL CONFORM TO CONNDOT " STANDARD SPECIFICATIONS FOR ROADS, BRIDGES AND INCIDENTAL CONSTRUCTION"; FORM 816 DATED 2004 AND ALL SUBSEQUENT AMENDMENTS OR MODIFICATIONS THERETO.